

Soft Start Controllers



### 35.1 Solid-State Controllers

Product Overview .....	<b>V6-T35-2</b>
Type S701, Soft Start Controllers .....	<b>V6-T35-3</b>
Type S701, Soft Start Controllers with Auxiliary Contact .....	<b>V6-T35-9</b>
Type S701, Soft Start Controllers with Brake .....	<b>V6-T35-12</b>
Type S511, Semiconductor Reversing Contactors .....	<b>V6-T35-15</b>
DS6 Soft Start Controllers .....	<b>V6-T35-19</b>
DS7 Soft Start Controllers .....	<b>V6-T35-28</b>

### 35.2 Solid-State Starters

Product Overview .....	<b>V6-T35-38</b>
Type S801, Intelligent Technologies (IT) Soft Starters .....	<b>V6-T35-39</b>
Type S811, Intelligent Technologies (IT) Soft Starters with DIM .....	<b>V6-T35-67</b>



Learn  
Online



Drawings  
Online

Soft Start Controllers



### Contents

<i>Description</i>	<i>Page</i>
Soft Start Controllers	
Type S701, Soft Start Controllers	<b>V6-T35-3</b>
Type S701, Soft Start Controllers with Auxiliary Contact	<b>V6-T35-9</b>
Type S701, Soft Start Controllers with Brake	<b>V6-T35-12</b>
Type S511, Semiconductor Reversing Contactors	<b>V6-T35-15</b>
DS6 Soft Start Controllers	<b>V6-T35-19</b>
DS7 Soft Start Controllers	<b>V6-T35-28</b>

### Product Overview

#### Type S701

The S701 device is a reduced voltage soft start controller designed to control acceleration and deceleration of three-phase motors. The S701 provides the user with the ability to adjust initial torque, ramp up and down time, and also select kick start for high inertial loads.

#### Type S701 with Auxiliary Contact

The S701 device is a reduced voltage soft start controller designed to control acceleration and deceleration of three-phase motors. With the auxiliary contact, it is possible to control an external bypass to reduce heating and increase acceleration and deceleration times.

The unit provides the user with the ability to adjust initial torque, ramp up and down time and also select kick start for high inertia loads.

#### Type S701 with Brake

The S701 soft start controller with DC injection brake is designed to control acceleration and deceleration of three-phase motors. Brake current is adjustable from 0–50A DC. The ramp-up feature is adjustable from 0.5–10 seconds. Torque adjustment is adjustable with or without break loose (kick start) function.

#### Semiconductor Reversing Contactor

The S511 device is a semiconductor reversing contactor designed to switch three-phase motors forward and reverse. Unicore electronics and thermal design ensures high switching capacity and long lifetime.

#### DS6

Eaton’s DS6 line of reduced voltage solid-state soft start controllers is very compact, multi-functional, easy to install, and easy to commission. Designed to control the acceleration and deceleration of three-phase motors, the device is available for current ranges from 40 to 180 amperes.

#### DS7

Eaton’s DS7 line of reduced voltage solid-state soft start controllers is very compact, multi-functional, easy to install, and easy to commission. Designed to control the acceleration and deceleration of three-phase motors, the device is available for current ranges from 4–32A in four frame sizes.

**Type S701, Soft Start Controllers**



### Contents

<b>Description</b>	<b>Page</b>
Type S701, Soft Start Controllers	
Standards and Certifications . . . . .	<b>V6-T35-4</b>
Catalog Number Selection . . . . .	<b>V6-T35-4</b>
Product Selection . . . . .	<b>V6-T35-4</b>
Technical Data and Specifications . . . . .	<b>V6-T35-5</b>
Dimensions . . . . .	<b>V6-T35-8</b>
Type S701, Soft Start Controllers with Auxiliary Contact . . . . .	<b>V6-T35-9</b>
Type S701, Soft Start Controllers with Brake . . . . .	<b>V6-T35-12</b>
Type S511, Semiconductor Reversing Contactors . . . . .	<b>V6-T35-15</b>
DS6 Soft Start Controllers . . . . .	<b>V6-T35-19</b>
DS7 Soft Start Controllers . . . . .	<b>V6-T35-28</b>

## Type S701, Soft Start Controllers

### Product Description

The S701 device is a reduced voltage soft start controller designed to control acceleration and deceleration of three-phase motors. The S701 provides the user with the ability to adjust initial torque, ramp up and down time, and also select kick start for high inertial loads.

### Application Description

The S701 line of soft start controllers is specifically designed to be a low cost option for soft starting small (15 hp and down) three-phase motors. The S701 unit controls current on two of three motor phases to control the torque being applied to the motor, allowing for smooth starting of a motor. The S701 is designed to be used with a manual motor starter or a full voltage starter. These devices provide the necessary overload protection for the motor and also provide line isolation for the motor. Short-circuit protection can be provided by fuses or circuit breakers.

### Features

- Rated operational voltage up to 600 Vac
- Control voltage range from 24–480 Vac/Vdc
- Adjustable ramp times (0.5–10 seconds)
- Adjustable initial torque control (0–85%)
- Kick start feature
- Soft stop (0.5–10 seconds)
- Unlimited number of START/STOP operations per hour
- IP20 finger protection
- Fractional to 15 hp motors at 480V (20 hp at 600V)

### Benefits

- Reduced wear on belts, gears, chains, clutches, shafts and bearings
- Allows for controlling the inrush current to the motor
- Reduced water-hammer in pumping applications
- Less shock to product on conveyor lines and material handling gear

# 35.1

## Reduced Voltage Motor Starters

### Solid-State Controllers

35

#### Standards and Certifications

- IEC 947 compliant
- EN 60947-4-2
- CE marked
- CSA certified
- UL listed (E108212)
- cUL listed



#### Catalog Number Selection

##### S701 Soft Starters

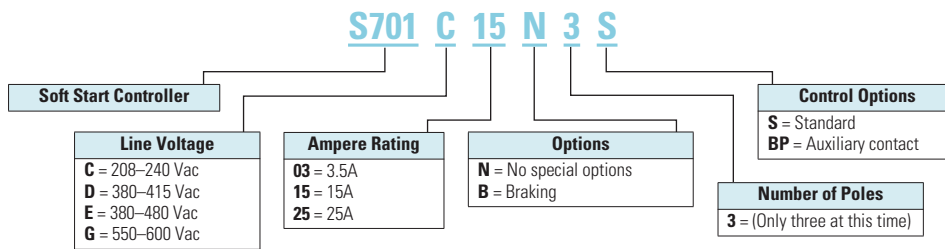

#### Product Selection

##### S701E15N3S

#### Soft Start Controllers



##### S701E25N3S



Max. Current	Line Voltage	Control Voltage (Vac/Vdc)	Three-Phase Motor kW Rating (50 Hz)			hp Rating (60 Hz)								Catalog Number
			230V	380–400V	440V	200V 1.0 SF	1.15 SF	230V 1.0 SF	1.15 SF	460V 1.0 SF	1.15 SF	575V 1.0 SF	1.15 SF	
3.5	208–240	24–240	7.5	N/A	N/A	1	1	1	1	N/A	N/A	N/A	N/A	S701C03N3S
3.5	380–415	24–300	N/A	1.1	N/A	N/A	N/A	N/A	N/A	1-1/2	1-1/2	N/A	N/A	S701D03N3S
3.5	440–480	24–300	N/A	N/A	1.5	N/A	N/A	N/A	N/A	2	2	N/A	N/A	S701E03N3S
3.5	500–600	24–300	N/A	N/A	N/A	N/A	N/A	N/A	N/A	N/A	N/A	2	2	S701G03N3S
15	208–240	24–240	4	N/A	N/A	3	3	3	3	N/A	N/A	N/A	N/A	S701C15N3S
15	380–480	24–300	N/A	5.5	7.5	N/A	N/A	N/A	N/A	10	7-1/2	N/A	N/A	S701E15N3S
15	500–600	24–300	N/A	N/A	N/A	N/A	N/A	N/A	N/A	N/A	N/A	10	10	S701G15N3S
25	208–240	24–240	7.5	N/A	N/A	5	5	7-1/2	5	N/A	N/A	N/A	N/A	S701C25N3S
25	380–480	24–300	N/A	11	12.5	N/A	N/A	N/A	N/A	15	15	N/A	N/A	S701E25N3S
25	500–600	24–300	N/A	N/A	N/A	N/A	N/A	N/A	N/A	N/A	N/A	20	20	S701G25N3S

## Technical Data and Specifications

### Soft Starters—S701\_03N3S

Description	S701C03N3S	S701D03N3S	S701E03N3S	S701G03N3S
Maximum current capacity	3.5	3.5	3.5	3.5
Trip Class				
10A	3.5	3.5	3.5	3.5
10	3.5	3.5	3.5	3.5
20	2.8	2.8	2.8	2.8
30	2.1	2.1	2.1	2.1
<b>Electrical Characteristics</b>				
Line voltage (Vac)	208–240	380–415	440–480	500–600
Operating frequency (Hz)	50/60	50/60	50/60	50/60
Leakage current	5 mA AC max.	5 mA AC max.	5 mA AC max.	5 mA AC max.
Minimum operational current	50 mA	50 mA	50 mA	50 mA
Control voltage (Vac/Vdc)	24–240	24–300	24–300	24–300
Pickup voltage max.	20.4 Vac/Vdc	20.4 Vac/Vdc	20.4 Vac/Vdc	20.4 Vac/Vdc
Dropout voltage min.	5 Vac/Vdc	5 Vac/Vdc	5 Vac/Vdc	5 Vac/Vdc
Max. control current for no operation	1 mA	1 mA	1 mA	1 mA
Response time max.	70 ms	70 ms	70 ms	70 ms
<b>Control Characteristics</b>				
Ramp time (secs)	0.5–10	0.5–10	0.5–10	0.5–10
Ramp settings (% LRT)	85%	85%	85%	85%
Kick start settings (% LRT)	85%	85%	85%	85%
Soft stop (secs)	0.5–10	0.5–10	0.5–10	0.5–10
<b>Environment Characteristics</b>				
Temperature—operating (no derating)	–30° to 40°C	–30° to 40°C	–30° to 40°C	–30° to 40°C
Current rating 50°C	N/A	N/A	N/A	N/A
Limited duty cycle 50°C	N/A	N/A	N/A	N/A
Current rating 60°C	N/A	N/A	N/A	N/A
Limited duty cycle 60°C	N/A	N/A	N/A	N/A
Temperature—storage	–30° to 80°C	–30° to 80°C	–30° to 80°C	–30° to 80°C
Altitude (meters)—no derating	2000	2000	2000	2000
Humidity	95% noncondensing	95% noncondensing	95% noncondensing	95% noncondensing
Operating position (no derating)	Vertical ±30°	Vertical ±30°	Vertical ±30°	Vertical ±30°
Impulse withstand voltage IEC 947-4-1	4000V	4000V	4000V	4000V
Rated insulation voltage (Ui)	660V	660V	660V	660V
Installation category	III	III	III	III
Vibration	IEC 68-2-6 5g 10–150 Hz	IEC 68-2-6 5g 10–150 Hz	IEC 68-2-6 5g 10–150 Hz	IEC 68-2-6 5g 10–150 Hz
Power dissipation for intermittent operation	4 W/A x duty cycle	4 W/A x duty cycle	4 W/A x duty cycle	4 W/A x duty cycle
Power dissipation for continuous operation	4 W/A x duty cycle	4 W/A x duty cycle	4 W/A x duty cycle	4 W/A x duty cycle
Cooling method	Natural convection	Natural convection	Natural convection	Natural convection
Degree of protection	IP20	IP20	IP20	IP20
Pollution degree	3	3	3	3
Agency approvals	UL, cUL, CE	UL, cUL, CE	UL, cUL, CE	UL, cUL, CE

## Soft Starters—S701\_15N3S

Description	S701C15N3S	S701E15N3S	S701G15N3S
Maximum current capacity	15	15	15
Trip Class			
10A	15	15	15
10	15	15	15
20	12	12	12
30	10	10	10
<b>Electrical Characteristics</b>			
Line voltage (Vac)	208–240	380–480	500–600
Operating frequency (Hz)	50/60	50/60	50/60
Leakage current	5 mA AC max.	5 mA AC max.	5 mA AC max.
Minimum operational current	50 mA	50 mA	50 mA
Control voltage (Vac/Vdc)	24–240	24–480	24–480
Pickup voltage max.	20.4 Vac/Vdc	20.4 Vac/Vdc	20.4 Vac/Vdc
Dropout voltage min.	5 Vac/Vdc	5 Vac/Vdc	5 Vac/Vdc
Max. control current for no operation	1 mA	1 mA	1 mA
Response time max.	70 ms	70 ms	70 ms
<b>Control Characteristics</b>			
Ramp time (secs)	0.5–10	0.5–10	0.5–10
Ramp settings (% LRT)	85%	85%	85%
Kick start settings (% LRT)	85%	85%	85%
Soft stop (secs)	0.5–10	0.5–10	0.5–10
<b>Environment Characteristics</b>			
Temperature—operating (no derating)	–30° to 40°C	–30° to 40°C	–30° to 40°C
Current rating 50°C	12.5A	12.5A	12.5A
Limited duty cycle 50°C	15A on-time max. 15 min. duty cycle max. 0.8	15A on-time max. 15 min. duty cycle max. 0.8	15A on-time max. 15 min. duty cycle max. 0.8
Current rating 60°C	10A	10A	10A
Limited duty cycle 60°C	15A on-time max. 15 min. duty cycle max. 0.65	15A on-time max. 15 min. duty cycle max. 0.65	15A on-time max. 15 min. duty cycle max. 0.65
Temperature—storage	–30° to 80°C	–30° to 80°C	–30° to 80°C
Altitude (meters)—no derating	2000	2000	2000
Humidity	95% noncondensing	95% noncondensing	95% noncondensing
Operating position (no derating)	Vertical ±30°	Vertical ±30°	Vertical ±30°
Impulse withstand voltage IEC 947-4-1	4000V	4000V	4000V
Rated insulation voltage (Ui)	660V	660V	660V
Installation category	III	III	III
Vibration	IEC 68-2-6 5g 10–150 Hz	IEC 68-2-6 5g 10–150 Hz	IEC 68-2-6 5g 10–150 Hz
Power dissipation for intermittent operation	2 W/A x duty cycle	2 W/A x duty cycle	2 W/A x duty cycle
Power dissipation for continuous operation	2 W/A	2 W/A	2 W/A
Cooling method	Natural convection	Natural convection	Natural convection
Degree of protection	IP20	IP20	IP20
Pollution degree	3	3	3
Agency approvals	UL, CSA, CE	UL, CSA, CE	UL, CSA, CE

## Soft Starters—S701\_25N3S

Description	S701C25N3S	S701E25N3S	S701G25N3S
Maximum current capacity	25	25	25
Trip Class			
10A	25	25	25
10	25	25	25
20	20	20	20
30	15	15	15
<b>Electrical Characteristics</b>			
Line voltage (Vac)	208–240	380–480	500–600
Operating frequency (Hz)	50/60	50/60	50/60
Leakage current	5 mA AC max.	5 mA AC max.	5 mA AC max.
Minimum operational current	50 mA	50 mA	50 mA
Control voltage (Vac/Vdc)	24–240	24–300	24–300
Pickup voltage max.	20.4 Vac/Vdc	20.4 Vac/Vdc	20.4 Vac/Vdc
Dropout voltage min.	5 Vac/Vdc	5 Vac/Vdc	5 Vac/Vdc
Max. control current for no operation	1 mA	1 mA	1 mA
Response time max.	70 ms	70 ms	70 ms
<b>Control Characteristics</b>			
Ramp time (secs)	0.5–10	0.5–10	0.5–10
Ramp settings (% LRT)	85%	85%	85%
Kick start settings (% LRT)	85%	85%	85%
Soft stop (secs)	0.5–10	0.5–10	0.5–10
<b>Environment Characteristics</b>			
Temperature—operating (no derating)	–30° to 40°C	–30° to 40°C	–30° to 40°C
Current rating 50°C	20A	20A	20A
Limited duty cycle 50°C	25A on-time max. 15 min. duty cycle max. 0.8	25A on-time max. 15 min. duty cycle max. 0.8	25A on-time max. 15 min. duty cycle max. 0.8
Current rating 60°C	17A	17A	17A
Limited duty cycle 60°C	25A on-time max. 15 min. duty cycle max. 0.65	25A on-time max. 15 min. duty cycle max. 0.65	25A on-time max. 15 min. duty cycle max. 0.65
Temperature—storage	–30° to 80°C	–30° to 80°C	–30° to 80°C
Altitude (meters)—no derating	2000	2000	2000
Humidity	95% noncondensing	95% noncondensing	95% noncondensing
Operating position (no derating)	Vertical ±30°	Vertical ±30°	Vertical ±30°
Impulse withstand voltage IEC 947-4-1	4000V	4000V	4000V
Rated insulation voltage (Ui)	660V	660V	660V
Installation category	III	III	III
Vibration	IEC 68-2-6 5g 10–150 Hz	IEC 68-2-6 5g 10–150 Hz	IEC 68-2-6 5g 10–150 Hz
Power dissipation for intermittent operation	2 W/A x duty cycle	2 W/A x duty cycle	2 W/A x duty cycle
Power dissipation for continuous operation	2 W/A	2 W/A	2 W/A
Cooling method	Natural convection	Natural convection	Natural convection
Degree of protection	IP20	IP20	IP20
Pollution degree	3	3	3
Agency approvals	UL, CSA, CE	UL, CSA, CE	UL, CSA, CE

**Dimensions**

Approximate Dimensions in Inches (mm)

**Soft Starters—S701...N3S**

<b>Catalog Number</b>	<b>W</b>	<b>H</b>	<b>D</b>	<b>Weight in Lbs (kg)</b>
<b>S701C03N3S</b>	0.89 (22.5)	3.94 (100)	5.01 (127)	0.6 (270)
<b>S701D03N3S</b>	0.89 (22.5)	3.94 (100)	5.01 (127)	0.6 (270)
<b>S701E03N3S</b>	0.89 (22.5)	3.94 (100)	5.01 (127)	0.6 (270)
<b>S701G03N3S</b>	0.89 (22.5)	3.94 (100)	5.01 (127)	0.6 (270)
<b>S701C15N3S</b>	1.77 (45)	3.94 (100)	5.04 (128)	1.52 (690)
<b>S701E15N3S</b>	1.77 (45)	3.94 (100)	5.04 (128)	1.52 (690)
<b>S701G15N3S</b>	1.77 (45)	3.94 (100)	5.04 (128)	1.52 (690)
<b>S701C25N3S</b>	3.54 (90)	3.94 (100)	5.04 (128)	2.53 (1150)
<b>S701E25N3S</b>	3.54 (90)	3.94 (100)	5.04 (128)	2.53 (1150)
<b>S701G25N3S</b>	3.54 (90)	3.94 (100)	5.04 (128)	2.53 (1150)



**Type S701, Soft Start Controllers with Auxiliary Contact**



## Contents

<b>Description</b>	<b>Page</b>
Type S701, Soft Start Controllers	<b>V6-T35-3</b>
Type S701, Soft Start Controllers with Auxiliary Contact	
Product Selection	<b>V6-T35-10</b>
Technical Data and Specifications	<b>V6-T35-10</b>
Dimensions	<b>V6-T35-11</b>
Type S701, Soft Start Controllers with Brake	<b>V6-T35-12</b>
Type S511, Semiconductor Reversing Contactors	<b>V6-T35-15</b>
DS6 Soft Start Controllers	<b>V6-T35-19</b>
DS7 Soft Start Controllers	<b>V6-T35-28</b>

## Type S701, Soft Start Controllers with Auxiliary Contact

### Product Description

The S701 device is a reduced voltage soft start controller designed to control acceleration and deceleration of three-phase motors. With the auxiliary contact, it is possible to control an external bypass to reduce heating and increase acceleration and deceleration times.

The unit provides the user with the ability to adjust initial torque, ramp up and down time and also select kick start for high inertia loads.

### Application Description

The S701 line of soft start controllers is specifically designed to be a low cost option for soft starting small (15 hp and down) three-phase motors. The auxiliary contact is designed to work in conjunction with an across-the-line contactor. The purpose of the contactor is to provide a parallel current path once the soft starter has brought the motor up to speed. Once the soft start controller reaches end of ramp, the auxiliary contact will close and send a signal to close the bypass contactor, thus providing a low impedance path for the current to the motor. The S701 unit controls current on two of three motor phases to control the torque being applied to the motor, allowing for smooth starting of a motor. The S701 is designed to be used with a manual motor protector or a full voltage starter. These devices provide the necessary overload protection for the motor and also provide line isolation for the motor. Short-circuit protection can be provided by fuses or circuit breakers.

### Features

- Rated operational voltage up to 600 Vac
- Control voltage range from 24–300 Vac/Vdc
- Adjustable ramp times (0.5–20 seconds)
- Adjustable initial torque control (0–85%)
- Kick start feature (0–85% adjustment)
- Kick start for 200 ms
- Soft stop (0.5–20 seconds)
- IP20 finger protection
- Available up to 30A (with Bypass installed)
- Auxiliary contact for up-to-speed indication

### Benefits

- Reduced wear on belts, gears, chains, clutches, shafts and bearings
- Bypass option allows for greater current capacity in the unit
- Bypass option helps to reduce heat in the enclosure
- Allows for controlling the inrush current to the motor
- Reduced water-hammer in pumping applications
- Less shock to product on conveyor lines and material handling gear

### Standards and Certifications

- IEC 947 compliant
- EN 60947-4-2
- CE marked
- UL listed (E108212)
- cUL listed



#### Product Selection

For S701 catalog number selection, see **Page V6-T35-5**.

S701

#### Soft Start Controllers with Auxiliary Contact



Max. Current	Line Voltage	Control Voltage (Vac/Vdc)	Three-Phase Motor kW Rating (50 Hz)			hp Rating		230V		460V		575V		Catalog Number
			230V	380–400V	440V	200V	1.15 SF	1.0 SF	1.15 SF	1.0 SF	1.15 SF	1.0 SF	1.15 SF	
<b>Ratings without Bypass</b>														
25	208–240	24–240	5.5	N/A	N/A	5	5	7-1/2	5	N/A	N/A	N/A	N/A	<b>S701C25N3BP</b>
25	380–480	24–300	N/A	12.5	12.5	N/A	N/A	N/A	N/A	15	15	N/A	N/A	<b>S701E25N3BP</b>
25	500–600	24–300	N/A	N/A	N/A	N/A	N/A	N/A	N/A	N/A	N/A	20	20	<b>S701G25N3BP</b>
<b>Ratings with Bypass</b>														
30	208–240	24–240	7.5	N/A	N/A	7-1/2	7-1/2	10	7-1/2	N/A	N/A	N/A	N/A	<b>S701C25N3BP</b>
30	380–480	24–300	N/A	15	15	N/A	N/A	N/A	N/A	20	15	N/A	N/A	<b>S701E25N3BP</b>
30	500–600	24–300	N/A	N/A	N/A	N/A	N/A	N/A	N/A	N/A	N/A	25	20	<b>S701G25N3BP</b>

#### Technical Data and Specifications

##### Soft Starters with Auxiliary Contact—S701\_25N3BP

Description	S701C25N3BP	S701E25N3BP	S701G25N3BP
Maximum current capacity with bypass (without bypass)	30 (25)	30 (25)	30 (25)
Trip Class			
10A	30 (25)	30 (25)	30 (25)
10	30 (25)	30 (25)	30 (25)
20	24 (20)	24 (20)	24 (20)
30	19.5 (15)	19.5 (15)	19.5 (15)
<b>Electrical Characteristics</b>			
Line voltage (Vac)	208–240	380–480	500–600
Operating frequency (Hz)	50/60	50/60	50/60
Leakage current	5 mA AC max.	5 mA AC max.	5 mA AC max.
Minimum operational current	50 mA	50 mA	50 mA
Control voltage (Vac/Vdc)	24–240	24–300	24–300
Pickup voltage max.	20.4 Vac/Vdc	20.4 Vac/Vdc	20.4 Vac/Vdc
Dropout voltage min.	5 Vac/Vdc	5 Vac/Vdc	5 Vac/Vdc
Max. control current for no operation	1 mA	1 mA	1 mA
Response time max.	70 ms	70 ms	70 ms

## Soft Starters with Auxiliary Contact—S701\_25N3BP, continued

Description	S701C25N3BP	S701E25N3BP	S701G25N3BP
<b>Control Characteristics</b>			
Ramp time (secs)	0.5–20	0.5–20	0.5–20
Ramp settings (% LRT)	85%	85%	85%
Kick start settings (% LRT)	85%	85%	85%
Soft stop (secs)	0.5–20	0.5–20	0.5–20
<b>Environmental Characteristics</b>			
Temperature—operating (no derating)	–30° to 40°C	–30° to 40°C	–30° to 40°C
Current rating 50°C	20A	20A	20A
Limited duty cycle 50°C	25A on-time max. 15 min. duty cycle max. 0.8	25A on-time max. 15 min. duty cycle max. 0.8	25A on-time max. 15 min. duty cycle max. 0.8
Current rating 60°C	17A	17A	17A
Limited duty cycle 60°C	25A on-time max. 15 min. duty cycle max. 0.65	25A on-time max. 15 min. duty cycle max. 0.65	25A on-time max. 15 min. duty cycle max. 0.65
Temperature—storage	–30° to 80°C	–30° to 80°C	–30° to 80°C
Altitude (meters)—no derating	2000	2000	2000
Humidity	95% noncondensing	95% noncondensing	95% noncondensing
Operating position (no derating)	Vertical ±30°	Vertical ±30°	Vertical ±30°
Impulse withstand voltage IEC 947-4-1	4000V	4000V	4000V
Rated insulation voltage (Ui)	660V	660V	660V
Installation category	III	III	III
Vibration	IEC 68-2-6 5g 10–150 Hz	IEC 68-2-6 5g 10–150 Hz	IEC 68-2-6 5g 10–150 Hz
Power dissipation for continuous operation	2 W/A without bypass	2 W/A without bypass	2 W/A without bypass
Power dissipation with semiconductor bypassed	5 W/A max. with bypass	5 W/A max. with bypass	5 W/A max. with bypass
Cooling method	Natural convection	Natural convection	Natural convection
Degree of protection	IP20	IP20	IP20
Pollution degree	3	3	3
Agency approvals	UL, cUL, CE	UL, cUL, CE	UL, cUL, CE

## Dimensions

Approximate Dimensions in Inches (mm)

## Soft Starters with Auxiliary Contact—S701\_25N3BP

Catalog Number	W	H	D	Weight in Lbs (kg)
S701C25N3BP	3.54 (89.9)	3.94 (100.1)	5.04 (128.0)	2.53 (1150)
S701E25N3BP	3.54 (89.9)	3.94 (100.1)	5.04 (128.0)	2.53 (1150)
S701G25N3BP	3.54 (89.9)	3.94 (100.1)	5.04 (128.0)	2.53 (1150)

Type S701, Soft Start Controllers with Brake



### Contents

<b>Description</b>	<b>Page</b>
Type S701, Soft Start Controllers .....	<b>V6-T35-3</b>
Type S701, Soft Start Controllers with Auxiliary Contact .....	<b>V6-T35-9</b>
Type S701, Soft Start Controllers with Brake	
Product Selection .....	<b>V6-T35-13</b>
Technical Data and Specifications .....	<b>V6-T35-13</b>
Dimensions .....	<b>V6-T35-14</b>
Type S511, Semiconductor Reversing Contactors .....	<b>V6-T35-15</b>
DS6 Soft Start Controllers .....	<b>V6-T35-19</b>
DS7 Soft Start Controllers .....	<b>V6-T35-28</b>

### Type S701, Soft Start Controllers with Brake

#### Product Description

The S701 soft start controller with DC injection brake is designed to control acceleration and deceleration of three-phase motors. Brake current is adjustable from 0–50A DC. The ramp-up feature is adjustable from 0.5–10 seconds. Torque adjustment is adjustable with or without break loose (kick start) function.

#### Application Description

The S701 line of soft start controllers is specifically designed to be a low cost option for soft starting small (15 hp and down) three-phase motors. The braking option is a DC injection system, allowing for fast stopping of a three-phase motor. The S701 unit controls current on two of the three phases to control the torque being applied to the motor, allowing for smooth starting of a motor. The S701 is designed to be used with a manual motor starter or a full voltage starter. These devices provide the necessary overload protection for the motor and also provide line isolation for the motor. Short-circuit protection can be provided by fuses or circuit breakers.

#### Features

- Rated operational voltage up to 480 Vac
- Control voltage range from 24–300 Vac/Vdc
- Adjustable ramp times (0.5–20 seconds)
- Adjustable initial torque control (0–85%)
- Kick start feature (0–85% adjustment)
- Kick start for 200 ms
- IP20 finger protection
- Braking control adjustable from 0–50A DC
- Slow speed: 7.5% or 10% of nominal speed

#### Benefits

- Reduced wear on bolts, gears, chains, clutches, shafts and bearings
- Braking option allows for quick stopping of loads
- Brake control can help eliminate expensive mechanical brakes
- Allows for controlling the inrush current to the motor
- Reduced water-hammer in pumping applications
- Less shock to product on conveyor lines and material handling gear

#### Standards and Certifications

- IEC 947 compliant
- EN 60947-4-2
- CE marked
- UL listed (E108212)
- cUL listed



### Product Selection

For S701 catalog number selection, see **Page V6-T35-5**.

#### S701E25B3S

#### Soft Start Controllers with Brake



Max. Current	Line Voltage	Control Voltage (Vac/Vdc)	Three-Phase Motor kW Rating (50 Hz)			hp Rating		230V		460V		Catalog Number
			230V	380–400V	440V	200V 1.0 SF	1.15 SF	1.0 SF	1.15 SF	1.0 SF	1.15 SF	
25	208–240	24–240	5.5	N/A	N/A	5	5	7-1/2	5	N/A	N/A	<b>S701C25B3S</b>
25	380–480	24–300	N/A	12.5	12.5	N/A	N/A	N/A	N/A	15	15	<b>S701E25B3S</b>

### Technical Data and Specifications

#### Soft Starters with Brake—S701\_25B3S

Description	S701C25B3S	S701E25B3S
Maximum current capacity	25	25
Trip Class		
10A	25	25
10	25	25
20	20	20
30	15	15
<b>Electrical Characteristics</b>		
Line voltage (Vac)	208–240	380–480
Operating frequency (Hz)	50/60	50/60
Leakage current	5 mA AC max.	5 mA AC max.
Minimum operational current	1A	1A
Control voltage (Vac/Vdc)	24–240	24–300
Pickup voltage max.	20.4 Vac/Vdc	20.4 Vac/Vdc
Dropout voltage min.	5 Vac/Vdc	5 Vac/Vdc
Max. control current for no operation	1 mA	1 mA
Response time max.	100 ms	100 ms
<b>Control Characteristics</b>		
Ramp time (secs)	0.5–10	0.5–10
Ramp settings (% LRT)	85%	85%
Kick start settings (% LRT)	85%	85%
Soft stop (secs)	0.5–10	0.5–10
Brake current	0–50 Vdc	0–50 Vdc

## Soft Starters with Brake—S701\_25B3S, continued

Description	S701C25B3S	S701E25B3S
<b>Environmental Characteristics</b>		
Temperature—operating	–30° to 40°C	–30° to 40°C
Current rating 50°C	20A	20A
Limited duty cycle 50°C	25A on-time max. 15 min. duty cycle max. 0.8	25A on-time max. 15 min. duty cycle max. 0.8
Current rating 60°C	17A	17A
Limited duty cycle 60°C	25A on-time max. 15 min. duty cycle max. 0.65	25A on-time max. 15 min. duty cycle max. 0.65
Temperature—storage	–30° to 80°C	–30° to 80°C
Altitude (meters)—no derating	2000	2000
Humidity	95% noncondensing	95% noncondensing
Operating position	Vertical ± 0°	Vertical ± 0°
Impulse withstand voltage IEC 947-4-1	4000V	4000V
Rated insulation voltage (Ui)	660V	660V
Installation category	III	III
Vibration	IEC 68-2-6 5g 10–150 Hz	IEC 68-2-6 5g 10–150 Hz
Power dissipation for intermittent operation	2 W/A x duty cycle	2 W/A x duty cycle
Power dissipation for continuous operation	2 W/A	2 W/A
Cooling method	Natural convection	Natural convection
Degree of protection	IP20	IP20
Pollution degree	3	3
Agency approvals	UL, cUL, CE	UL, cUL, CE

**Dimensions**

Approximate Dimensions in Inches (mm)

## Soft Starters with Brake—S701\_25B3S

Catalog Number	W	H	D	Weight in Lbs (kg)
S701C25B3S	3.54 (89.9)	3.94 (100.1)	5.04 (128.0)	2.53 (1150)
S701E25B3S	3.54 (89.9)	3.94 (100.1)	5.04 (128.0)	2.53 (1150)

**Contents**

<b>Description</b>	<b>Page</b>
Type S701, Soft Start Controllers .....	<b>V6-T35-3</b>
Type S701, Soft Start Controllers with Auxiliary Contact .....	<b>V6-T35-9</b>
Type S701, Soft Start Controllers with Brake .....	<b>V6-T35-12</b>
Type S511, Semiconductor Reversing Contactors	
Product Selection .....	<b>V6-T35-16</b>
Technical Data and Specifications .....	<b>V6-T35-16</b>
Dimensions .....	<b>V6-T35-17</b>
DS6 Soft Start Controllers .....	<b>V6-T35-19</b>
DS7 Soft Start Controllers .....	<b>V6-T35-28</b>

**Type S511, Semiconductor Reversing Contactors**

**Product Description**

The S511 device is a semiconductor reversing contactor designed to switch three-phase motors forward and reverse. Unicore electronics and thermal design ensures high switching capacity and long lifetime.

**Application Description**

The S511 line of solid-state reversing contactors is specifically designed for high speed operations or when long contactor life is required. The reversing contactors are intended for small motor applications (5 hp and below). The S511 unit can be used in a variety of applications including fans, pumps, conveyors, doors, hoists, cranes, etc. It is designed to be used with a manual motor starter or a full voltage starter. These devices provide the necessary overload protection for the motor and also provide line isolation for the motor. Short-circuit protection can be provided by fuses or circuit breakers.

**Features**

- Rated operational voltage up to 480 Vac
- Control voltage ranges of 5–24 Vdc and 24–240 Vac/Vdc
- Unlimited number of START/STOP operations per hour
- IP20 finger protection
- AC-3 current rating of 10A
- AC-4 current rating of 8A

**Benefits**

- Extremely high switching rates possible
- Very long life expectancy and no contacts or movable parts to replace
- Compact design (45 mm wide) leads to significant panel savings

**Standards and Certifications**

- IEC 947 compliant
- EN 60947-4-2
- CE marked
- CSA certified
- UL listed



## Product Selection

## Reversing Solid-State Contactors

Max. Current	Line Voltage	Control Voltage	Three-Phase Motor kW Rating (50 Hz)			hp Rating		230V		460V		Catalog Number
			230V	380–400V	440V	200V		1.0 SF	1.15 SF	1.0 SF	1.15 SF	
						1.0 SF	1.15 SF					
10	208–480	5–24 Vdc	2.2	4	4	2	2	3	2	5	5	S511E10N3D
10	208–480	24–240 Vac/Vdc	2.2	4	4	2	2	3	2	5	5	S511E10N3S

## Technical Data and Specifications

## Semiconductor Reversing Contactors—S511E10N3

Description	S511E10N3D	S511E10N3S
Maximum current capacity	10	10
Trip Class		
10A	10	10
10	10	10
20	8	8
30	6.5	6.5
<b>Electrical Characteristics</b>		
Line Voltage (Vac)	208–480	208–480
Operating frequency (Hz)	50/60	50/60
Control voltage	5–24 Vdc	24–240 Vac/Vdc
Pickup voltage max.	4.25 Vdc	20.4 Vac/Vdc
Dropout voltage min.	1.5 Vdc	7.2 Vac/Vdc
Max. control voltage	26.4 Vdc	253 Vac/Vdc
Response time max.	1/2 cycle	1 cycle
Interlock time max.	80 ms	150 ms
<b>Control Characteristics</b>		
Operation current AC-3	10	10
Operation current AC-4	8	8
Duty cycle	Continuous operation	Continuous operation
Leakage current	1 mA AC max.	1 mA AC max.
Minimum operation current	10 mA AC	10 mA AC
<b>Environmental Characteristics</b>		
Temperature—operating	0° to 60°C	0° to 60°C
Temperature—storage	–20° to 80°C	–20° to 80°C
Altitude (meters)	2000	2000
Humidity	95% noncondensing	95% noncondensing
Operating position	Vertical ±30°	Vertical ±30°
Impulse withstand voltage IEC 947-4-1	4000V	4000V
Rated insulation voltage (Ui)	660V	660V
Installation category	III	III
Vibration	IEC 68-2-6 5g 10–150 Hz	IEC 68-2-6 5g 10–150 Hz
Power dissipation for intermittent operation	2.2 W/A x duty cycle	2.2 W/A x duty cycle
Power dissipation for continuous operation	2.2 W/A	2.2 W/A
Cooling method	Natural convection	Natural convection
Degree of protection	IP20	IP20
Pollution degree	3	3
Agency approvals	UL, CSA, CE	UL, CSA, CE



### Mounting Instructions

**IMPORTANT:** The controller is designed for vertical mounting in free air. If the controller is mounted horizontally, the load current must be reduced to 50% of rated current.

### Recommended Mounting Distances

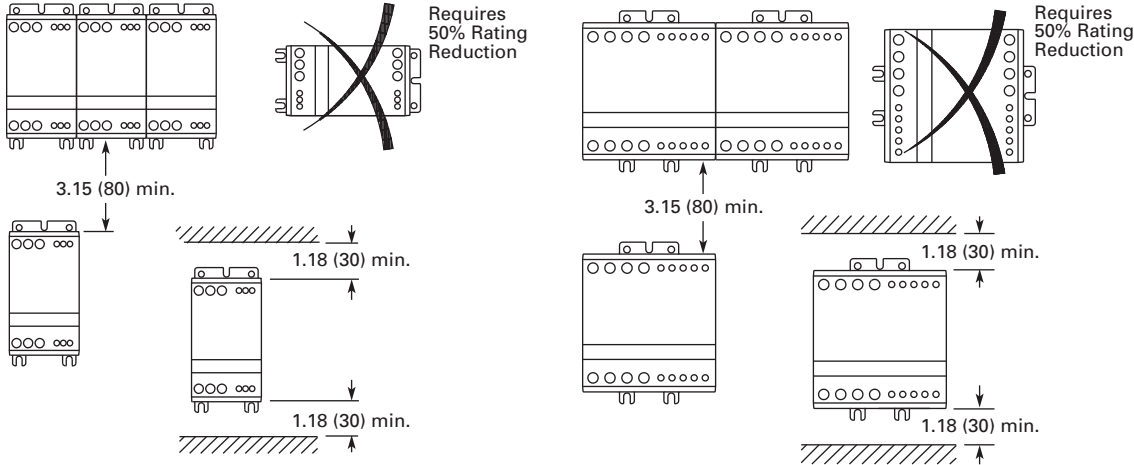

### Dimensions

Approximate Dimensions in Inches (mm)

### Semiconductor Reversing Contactors—S511E10N3

Catalog Number	W	H	D	Weight in Lbs (kg)
S511E10N3D	1.77 (45.0)	3.94 (100.1)	5.04 (128.0)	1.52 (690)
S511E10N3S	1.77 (45.0)	3.94 (100.1)	5.04 (128.0)	1.52 (690)

Also refer to dimension drawings on [Page V6-T35-18](#).

### Cable Requirements and Sizing

75°C	AWG (mm <sup>2</sup> )	AWG (mm <sup>2</sup> )
	18–12 (0.75–4)	20–16 (0.5–1.5)
	2–18 (2 x 1)	2 x 20–18 (2 x 0.5–0.75)
	18–10 (0.75–4)	20–16 (0.5–1.5)
	2 x 18–14 (2 x 0.75–2.5)	2 x 20–16 (2 x 0.5–1.5)
	18–10 (0.75–4)	20–16 (0.5–1.5)
	2 x 18–16 (0.75–6)	2 x 20–16 (2 x 0.5–1.5)
	Posidrive 1 4.4 in-lb. max. 0.5 Nm max.)	N/A
	4 mm 4.4 in-lb max. (0.5 Nm max.)	3 mm 3.5 in-lb max. (0.4 Nm max.)

# 35.1

## Reduced Voltage Motor Starters

### Solid-State Controllers

35

Approximate Dimensions in Inches (mm)

#### 22.5 mm Frame

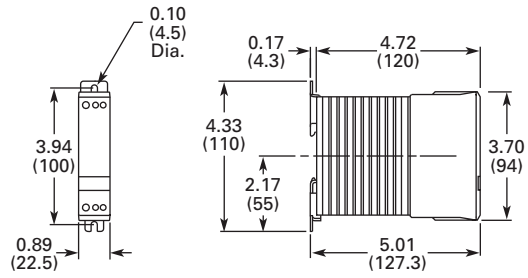

#### 90 mm Frame

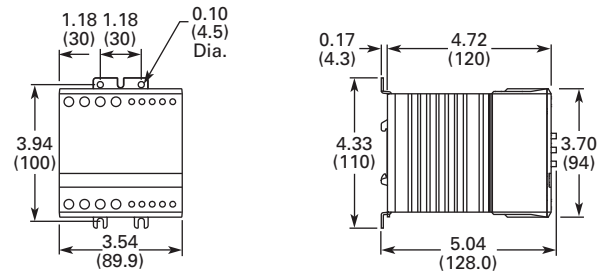
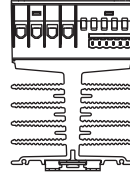

#### 45 mm Frame

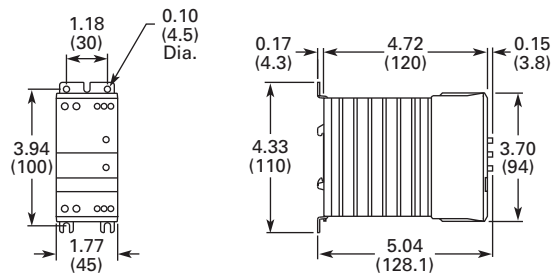
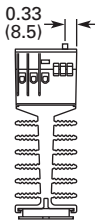

### DS6 Soft Start Controllers



## DS6 Soft Start Controllers

### Product Description

Eaton's DS6 line of reduced voltage solid-state soft start controllers is very compact, multi-functional, easy to install, and easy to commission. Designed to control the acceleration and deceleration of three-phase motors, the device is available for current ranges from 40 to 180 amperes.

### Application Description

With its small size, it can easily fit in place of existing soft starters, wye-delta starters, or across-the-line NEMA® and IEC starters. This feature allows easy upgrades to existing systems. The product is designed to be wired in the three-phase line feeding the three motor input leads as is done for normal across-the-line starting. The starter uses silicon controlled rectifiers (SCRs) to ramp the voltage to the motor, providing smooth acceleration and deceleration of the load. After the motor is started, the internal run bypass contactor closes, resulting in the motor running directly across-the-line. Internal run bypass significantly reduces the heat generated as compared to non-bypass starters. The soft stop option allows for a ramp stop time that may be longer than the coast-to-stop time. An external over-load protection is needed.

## Contents

### Description

<i>Description</i>	<i>Page</i>
Type S701, Soft Start Controllers .....	<b>V6-T35-3</b>
Type S701, Soft Start Controllers with Auxiliary Contact .....	<b>V6-T35-9</b>
Type S701, Soft Start Controllers with Brake .....	<b>V6-T35-12</b>
Type S511, Semiconductor Reversing Contactors .....	<b>V6-T35-15</b>
DS6 Soft Start Controllers	
Features and Benefits .....	<b>V6-T35-20</b>
Standards and Certifications .....	<b>V6-T35-20</b>
Instructional Leaflets .....	<b>V6-T35-20</b>
Product Selection .....	<b>V6-T35-21</b>
Technical Data and Specifications .....	<b>V6-T35-23</b>
Dimensions .....	<b>V6-T35-27</b>
DS7 Soft Start Controllers .....	<b>V6-T35-28</b>

### Operation

#### Voltage Ramp Start

This start method provides a voltage ramp to the motor, resulting in a constant torque increase. This most commonly used form of soft start mode allows you to set the initial voltage value and the duration of the ramp to full voltage conditions.

Bypass contactor(s) close after ramp time has elapsed.

- Adjustable initial voltage 30–92% of full voltage
- Adjustable ramp time 1–30 seconds

#### Start Ramp

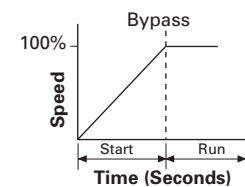

#### Soft Stop

Allows for a controlled stopping of load. Used when a stop-time that is greater than the coast-to-stop time is desired. Often used with high friction loads where a sudden stop may cause system or product damage. Setting the soft stop time to a value of 0 turns off this feature.

- Soft stop time = 0–30 seconds

#### Stop Ramp

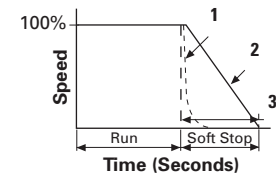

- 1 = Coast to Stop (Speed)
- 2 = Soft Stop Ramp (Voltage)
- 3 = Soft Stop Time

**Features and Benefits**

- Run bypass mode greatly reduces internal heating created by the power dissipation across the SCRs. The bypass contactor directly connects the motor to the line and improves system efficiency by reducing internal power losses
- Less heat minimizes enclosure size and cooling requirements, and maximizes the life of all devices in the enclosure
- LED displays device status and provides fault indication
- Variable ramp times and voltage control (torque control) settings provide unlimited starting configurations, allowing for maximum application flexibility
- Soft stop control suits applications where an abrupt stop of the load is not acceptable. Soft acceleration and deceleration reduces wear on belts, gears, chains, clutches, shafts, and bearings
- Minimizes the peak inrush current's stress on the power system
- Manages peak starting torque to diminish mechanical system wear and damage
- 24 Vdc control module enhances personnel and equipment safety

**Protective Features**

- There are two auxiliary relays—
  - First relay is a TOR relay which closes when the TOR is achieved (internal bypass relays close)
  - The second relay is a RUN relay which closes when the RUN signal is initiated and opens when RUN signal is removed. It remains closed during stop ramp time, if set to a value greater than 0. The RUN relay will also open if a fault occurs
- Mains connection—The mains connection is monitored for an open condition and/or undervoltage
- Motor connection—The motor connection is monitored for an open condition
- SCR faults—SCR performance is monitored during the ramp cycle for proper operation
- Heat sink over/under temperature—High ambient temperatures, extended ramp times, and high duty cycle conditions may cause the DS6 to exceed its thermal rating. When temperature goes under  $-5^{\circ}\text{C}$ , unit will trip as well. The DS6 is equipped with sensors that monitor the temperature of the device. The soft starter will trip in over/under temperature conditions, preventing device failure
- Bypass relay—The DS6 can detect if the bypass relay fails to close after the ramp start or opens while the motor is running. The DS6 will trip on a bypass dropout fault if either of these conditions occur. The device does not start when bypass relay is closed and start signal is applied
- 24 Vdc low voltage—If the control voltage falls below 20 Vdc at any time during operation, the unit will fault

**Standards and Certifications**

- IEC 60947-4-2
- EN 60947-4-2
- UL listed (E251034)
- CSA certified
- CE marked
- C-Tick

**Instructional Leaflets**

- Instruction Leaflet IL03901001E

### Product Selection

#### DS6 Soft Start Horsepower Ratings

Please refer to Application Note AP0390001E for additional information on proper size selection.

DS6 25–75 hp Model



#### DS6 Soft Start Controllers—Horsepower Ratings— 10 Second Ramp, 1 Start per Hour, 300% Current Limit at 40°C

Rated Current (A)	Motor Power (hp)			Maximum Allowable Breaker Size ①	Maximum Allowable Fuse Size ①	Recommended XTOB Overload	Recommended C440 Overload	Catalog Number
	200V	230V	460V					
40	10	10	30	HFD3150L	150A Class RK5	XTOB040DC1 ②	C440A1A045SAX	DS6-34DSX041N0-N
52	15	20	40	HFD3200L	200A Class RK5	XTOB057DC1 ②	C440B1A100SAX	DS6-34DSX055N0-N
65	20	25	50	HJD3250	200A Class RK5	XTOB065DC1 ②	C440B1A100SAX	DS6-34DSX068N0-N
77	25	30	60	HKD3300	300A Class RK5	XTOB100GC1S	C440B1A100SAX	DS6-34DSX081N0-N
96	30	30	75	HKD3350	350A Class RK5	XTOB100GC1S	C440B1A100SAX	DS6-34DSX099N0-N
124	40	50	100	HKD3400	500A Class RK5	XTOB125GC1S	C440A1A005SAX ④	DS6-34DSX134N0-N
156	50	60	125	HLD3450	500A Class RK5	XTOB160LC1 ③	C440A1A005SAX ④	DS6-34DSX161N0-N
180	60	75	150	HLD3500	500A Class RK5	XTOB220LC1 ③	C440A1A005SAX ④	DS6-34DSX196N0-N

DS6 100–150 hp Model



#### 10 Second Ramp, 1 Start per Hour, 400% Current Limit at 40°C

Rated Current (A)	Motor Power (hp)			Maximum Allowable Breaker Size ①	Maximum Allowable Fuse Size ①	Recommended XTOB Overload	Recommended C440 Overload	Catalog Number
	200V	230V	460V					
27	7.5	10	20	HFD3150L	150A Class RK5	XTOB040DC1	C440A1A045SAX	DS6-34DSX041N0-N
34	10	10	30	HFD3200L	200A Class RK5	XTOB040DC1	C440A1A045SAX	DS6-34DSX055N0-N
40	15	15	30	HJD3250	200A Class RK5	XTOB057DC1 ②	C440A1A045SAX	DS6-34DSX068N0-N
52	15	20	40	HKD3300	300A Class RK5	XTOB057DC1 ②	C440B1A100SAX	DS6-34DSX081N0-N
65	20	25	50	HKD3350	350A Class RK5	XTOB100GC1S	C440B1A100SAX	DS6-34DSX099N0-N
80	30	30	75	HKD3350	500A Class RK5	XTOB100GC1S	C440B1A100SAX	DS6-34DSX134N0-N
96	30	40	75	HLD3450	500A Class RK5	XTOB100GC1S	C440B1A100SAX	DS6-34DSX161N0-N
124	40	50	100	HLD3500	500A Class RK5	XTOB150GC1S	C440A1A005SAX ④	DS6-34DSX196N0-N

#### Notes

- ① Maximum values may be higher than allowed per NEC® 430.52 and UL 508A 31.1.
- ② XTOBXDIND Panel Mounting Adapter must be used with this overload.
- ③ XTOBXTLL line and load lugs must be used with this overload.
- ④ ZEB-XCT300 current transformer must be used with this overload.

**DS6 Soft Start kW Ratings**

Please refer to Application Note AP03900001E for additional information on proper size selection.

**DS6 25–75 hp Model****DS6 Soft Start Controllers—kW Ratings According to IEC 60947-4-2—10 Second Ramp, 1 Start per Hour, 300% Current Limit at 40°C**

Rated Current (A)	Motor Power (kW)		Maximum Allowable Breaker Size ①	Maximum Allowable Fuse Size ①	Recommended XTOB Overload	Recommended C440 Overload	Catalog Number
	230V	400V					
41	11	22	HFD3150L	150A Class RK5	XTOB057DC1 ②	C440A1A045SAX	DS6-34DSX041N0-N
55	15	30	HFD3200L	200A Class RK5	XTOB057DC1 ②	C440B1A100SAX	DS6-34DSX055N0-N
68	15	37	HJD3250	200A Class RK5	XTOB070GC1 ②	C440B1A100SAX	DS6-34DSX068N0-N
81	22	45	HKD3300	300A Class RK5	XTOB100GC1S	C440B1A100SAX	DS6-34DSX081N0-N
99	30	55	HKD3350	350A Class RK5	XTOB100GC1S	C440B1A100SAX	DS6-34DSX099N0-N
134	30	75	HKD3400	500A Class RK5	XTOB150GC1S	C440A1A005SAX ④	DS6-34DSX134N0-N
160	45	90	HLD3450	500A Class RK5	XTOB160LC1 ③	C440A1A005SAX ④	DS6-34DSX161N0-N
196	55	110	HLD3500	500A Class RK5	XTOB220LC1 ③	C440A1A005SAX ④	DS6-34DSX196N0-N

**DS6 100–150 hp Model****10 Second Ramp, 1 Start per Hour, 400% Current Limit at 40°C**

Rated Current (A)	Motor Power (kW)		Maximum Allowable Breaker Size ①	Maximum Allowable Fuse Size ①	Recommended XTOB Overload	Recommended C440 Overload	Catalog Number
	230V	400V					
28.8	7.5	11	HFD3150L	150A Class RK5	XTOB040DC1	C440A1A045SAX	DS6-34DSX041N0-N
37.5	11	18.5	HFD3200L	200A Class RK5	XTOB040DC1	C440A1A045SAX	DS6-34DSX055N0-N
46	11	22	HJD3250	200A Class RK5	XTOB057DC1 ②	C440B1A100SAX	DS6-34DSX068N0-N
56	15	30	HKD3300	300A Class RK5	XTOB065DC1 ②	C440B1A100SAX	DS6-34DSX081N0-N
68	18.5	37	HKD3350	350A Class RK5	XTOB100GC1S	C440B1A100SAX	DS6-34DSX099N0-N
90	22	45	HKD3350	500A Class RK5	XTOB100GC1S	C440B1A100SAX	DS6-34DSX134N0-N
106	30	55	HLD3450	500A Class RK5	XTOB160LC1 ③	C440A1A005SAX ④	DS6-34DSX161N0-N
134	37	75	HLD3500	500A Class RK5	XTOB160LC1 ③	C440A1A005SAX ④	DS6-34DSX196N0-N

**Considerations**

1. Either XTOB, C306 or C440 series or equivalent overload protection devices may be selected.
2. Contactor is optional for normal applications. It is recommended for mains isolation.

**Power Supply**

Eaton's PSG and ELC power supplies are recommended as a compact and low-cost source for 24 Vdc power. The light-weight, DIN rail mounted devices have a wide input voltage range, and robust screw terminals make these power supplies easy to install and use. These power supplies are available in 1A and 2A models.

**Power Supply Selection**

Description	Catalog Number
85–264V input and 24V output	ELC-PS01
380–480V input and 24V output	PSS25F
100–240 Vac input and 24 Vdc output	PSG60E
380–480 Vac input and 24 Vdc output	PSG60F

**Notes**

- ① Maximum values may be higher than allowed per NEC 430.52 and UL 508A 31.1.
- ② XTOBXDIND Panel Mounting Adapter must be used with this overload.
- ③ XTOBXTLL line and load lugs must be used with this overload.
- ④ ZEB-XCT300 current transformer must be used with this overload.

## Technical Data and Specifications

## DS6 Soft Start Controllers

Description	Unit	DS6-34DSX041N0-N	DS6-34DSX055N0-N	DS6-34DSX068N0-N	DS6-34DSX081N0-N
<b>General</b>					
Standards		IEC/EN 60947-4-2	IEC/EN 60947-4-2	IEC/EN 60947-4-2	IEC/EN 60947-4-2
Certifications		UL/CE/C-Tick/CSA	UL/CE/C-Tick/CSA	UL/CE/C-Tick/CSA	UL/CE/C-Tick/CSA
Ambient temperature (operation)	°C	0 to 40°C, above 40°C de-rate linearly by 1% of rated current per Celsius to 60°C	0 to 40°C, above 40°C de-rate linearly by 1% of rated current per Celsius to 60°C	0 to 40°C, above 40°C de-rate linearly by 1% of rated current per Celsius to 60°C	0 to 40°C, above 40°C de-rate linearly by 1% of rated current per Celsius to 60°C
Ambient temperature (storage)	°C	-25 to +55°C	-25 to +55°C	-25 to +55°C	-25 to +55°C
Altitude		0–1000m, above 1000m de-rate linearly by 1% of rated current per 100m to a maximum of 2000m	0–1000m, above 1000m de-rate linearly by 1% of rated current per 100m to a maximum of 2000m	0–1000m, above 1000m de-rate linearly by 1% of rated current per 100m to a maximum of 2000m	0–1000m, above 1000m de-rate linearly by 1% of rated current per 100m to a maximum of 2000m
Installation		Vertical	Vertical	Vertical	Vertical
Protection degree		IP 20	IP 20	IP 20	IP 20
Protection against contact		Back of hand and finger-proof (from front face)	Back of hand and finger-proof (from front face)	Back of hand and finger-proof (from front face)	Back of hand and finger-proof (from front face)
Overvoltage category/pollution degree		II/2	II/2	II/2	II/2
Shock resistance		8g/11 ms	8g/11 ms	8g/11 ms	8g/11 ms
Vibration resistance according to EN 60721-3-2		2M2	2M2	2M2	2M2
Dimensions in inches (mm) (W x H x D)		3.66 x 6.89 x 5.47 (93.0 x 175.0 x 138.9)	3.66 x 6.89 x 5.47 (93.0 x 175.0 x 138.9)	3.66 x 6.89 x 5.47 (93.0 x 175.0 x 138.9)	3.66 x 6.89 x 5.47 (93.0 x 175.0 x 138.9)
Weight in lbs (kg)		4.00 (1.8)	4.00 (1.8)	4.00 (1.8)	4.00 (1.8)
<b>Main Circuit</b>					
Rated operation voltage	V	200–460 Vac	200–460 Vac	200–460 Vac	200–460 Vac
Mains frequency	Hz	50/60 Hz	50/60 Hz	50/60 Hz	50/60 Hz
Rated impulse withstand voltage	$U_{imp} 1.2/50 \mu s$	4 kV	4 kV	4 kV	4 kV
Rated operation current	$I_e$	40	52	65	77
<b>Motor Power Ratings</b>					
200V	hp	10	15	20	25
230V	hp	10	20	25	30
460V	hp	30	40	50	60
230V	kW	11	15	15	22
400V	kW	22	30	37	45
Overload cycle according to EN 60947-4-2		40A: AC53a; 3–5; 75–10	52A: AC53a; 3–5; 75–10	65A: AC53a; 3–5; 75–10	77A: AC53a; 3–5; 75–10

## DS6 Soft Start Controllers, continued

Description	Unit	DS6-34DSX041N0-N	DS6-34DSX055N0-N	DS6-34DSX068N0-N	DS6-34DSX081N0-N
<b>Wire Specifications</b>					
Power terminals (box terminals)					
Single conductor	AWG	12–2/0	12–2/0	12–2/0	12–2/0
Terminal torque	lb-in	53–80	53–80	53–80	53–80
Control-signals					
Single conductor	AWG	16 min.	16 min.	16 min.	16 min.
Terminal torque	lb-in	3.5	3.5	3.5	3.5
<b>Powerpart</b>					
Rated impulse withstand voltage	$U_{imp} 1.2/50 \mu s$	4 kV	4 kV	4 kV	4 kV
<b>Control Commands</b>					
Supply voltage control board $U_s$					
Nominal voltage	Vdc	+24 Vdc +10%/–15%	+24 Vdc +10%/–15%	+24 Vdc +10%/–15%	+24 Vdc +10%/–15%
Nominal current ramp, TOR	mA	65	65	65	65
Current peak (closing shorting contactors)		600 mA/50 ms	600 mA/50 ms	600 mA/50 ms	600 mA/50 ms
Voltage to the control terminals (rated control voltage)					
DC driven		+24 Vdc +10%/–15%	+24 Vdc +10%/–15%	+24 Vdc +10%/–15%	+24 Vdc +10%/–15%
Input current at 24 Vdc	mA	14	14	14	14
<b>Relay Outputs</b>					
Number of relays		2 (TOR, ready)	2 (TOR, ready)	2 (TOR, ready)	2 (TOR, ready)
Maximum voltage	V	250 Vac, 60 Vdc	250 Vac, 60 Vdc	250 Vac, 60 Vdc	250 Vac, 60 Vdc
Maximum current	A	3 amps, resistive	3 amps, resistive	3 amps, resistive	3 amps, resistive
<b>Soft Start Functions</b>					
Ramp times					
Start ramp	s	1–30	1–30	1–30	1–30
Stop ramp	s	0–30	0–30	0–30	0–30
Initial voltage % line voltage		30–92%	30–92%	30–92%	30–92%



## DS6 Soft Start Controllers, continued

Description	Unit	DS6-34DSX099N0-N	DS6-34DSX134N0-N	DS6-34DSX161N0-N	DS6-34DSX196N0-N
<b>General</b>					
Standards		IEC/EN 60947-4-2	IEC/EN 60947-4-2	IEC/EN 60947-4-2	IEC/EN 60947-4-2
Certifications/markings		UL/CE/C-Tick/CSA	UL/CE/C-Tick/CSA	UL/CE/C-Tick/CSA	UL/CE/C-Tick/CSA
Ambient temperature (operation)	°C	0 to 40°C, above 40°C de-rate linearly by 1% of rated current per Celsius to 60°C	0 to 40°C, above 40°C de-rate linearly by 1% of rated current per Celsius to 60°C	0 to 40°C, above 40°C de-rate linearly by 1% of rated current per Celsius to 60°C	0 to 40°C, above 40°C de-rate linearly by 1% of rated current per Celsius to 60°C
Ambient temperature (storage)	°C	-25 to +55°C	-25 to +55°C	-25 to +55°C	-25 to +55°C
Altitude		0–1000m, above 1000m de-rate linearly by 1% of rated current per 100m to a maximum of 2000m	0–1000m, above 1000m de-rate linearly by 1% of rated current per 100m to a maximum of 2000m	0–1000m, above 1000m de-rate linearly by 1% of rated current per 100m to a maximum of 2000m	0–1000m, above 1000m de-rate linearly by 1% of rated current per 100m to a maximum of 2000m
Installation		Vertical	Vertical	Vertical	Vertical
Protection degree		IP 20	IP 20	IP 20	IP 20
Protection against contact		Back of hand and finger-proof (from front face)	Back of hand and finger-proof (from front face)	Back of hand and finger-proof (from front face)	Back of hand and finger-proof (from front face)
Overvoltage category/pollution degree		II/2	II/2	II/2	II/2
Shock resistance		8g/11 ms	8g/11 ms	8g/11 ms	8g/11 ms
Vibration resistance according to EN 60721-3-2		2M2	2M2	2M2	2M2
Dimensions in inches (mm) (W x H x D)		3.66 x 6.89 x 5.47 (93.0 x 175.0 x 138.9)	4.25 x 8.46 x 7.01 (108.0 x 214.9 x 178.1)	4.25 x 8.46 x 7.01 (108.0 x 214.9 x 178.1)	4.25 x 8.46 x 7.01 (108.0 x 214.9 x 178.1)
Weight in lbs (kg)		4.00 (1.8)	8.16 (3.7)	8.16 (3.7)	8.16 (3.7)
<b>Main Circuit</b>					
Rated operation voltage	V	200–460 Vac	200–460 Vac	200–460 Vac	200–460 Vac
Mains frequency	Hz	50/60 Hz	50/60 Hz	50/60 Hz	50/60 Hz
Rated impulse withstand voltage	$U_{imp} 1.2/50 \mu s$	4 kV	4 kV	4 kV	4 kV
Rated operation current	$I_e$	96	124	156	180
<b>Motor Power Ratings</b>					
200V	hp	30	40	50	60
230V	hp	30	50	60	75
460V	hp	75	100	125	150
230V	kW	30	30	45	55
400V	kW	55	75	90	110
Overload cycle according to EN 60947-4-2		96A: AC53a; 3–5; 75–10	124A: AC53a; 3–5; 75–10	156A: AC53a; 3–5; 75–10	180A: AC53a; 3–5; 75–10

## DS6 Soft Start Controllers, continued

Description	Unit	DS6-34DSX099N0-N	DS6-34DSX134N0-N	DS6-34DSX161N0-N	DS6-34DSX196N0-N
<b>Wire Specifications</b>					
Power terminals (box terminals)					
Single conductor	AWG	12–2/0	12 AWG–350 kcmil	12 AWG–350 kcmil	12 AWG–350 kcmil
Terminal torque	lb-in	53–80	44–123	44–123	44–123
Control-signals					
Single conductor	AWG	16 min.	16 min.	16 min.	16 min.
Terminal torque	lb-in	3.5	3.5	3.5	3.5
<b>Powerpart</b>					
Rated impulse withstand voltage	$U_{imp} 1.2/50 \mu s$	4 kV	4 kV	4 kV	4 kV
<b>Control Commands</b>					
Supply voltage control board $U_s$					
Nominal voltage	Vdc	+24 Vdc +10%/–15%	+24 Vdc +10%/–15%	+24 Vdc +10%/–15%	+24 Vdc +10%/–15%
Nominal current ramp, TOR	mA	65	65	65	65
Current peak (closing shorting contactors)		600 mA/50 ms	600 mA/50 ms	600 mA/50 ms	600 mA/50 ms
Voltage to the control terminals (rated control voltage)					
DC driven		+24 Vdc +10%/–15%	+24 Vdc +10%/–15%	+24 Vdc +10%/–15%	+24 Vdc +10%/–15%
Input current at 24 Vdc	mA	14	14	14	14
<b>Relay Outputs</b>					
Number of relays		2 (TOR, ready)	2 (TOR, ready)	2 (TOR, ready)	2 (TOR, ready)
Maximum voltage	V	250 Vac, 60 Vdc	250 Vac, 60 Vdc	250 Vac, 60 Vdc	250 Vac, 60 Vdc
Maximum current	A	3 amps, resistive	3 amps, resistive	3 amps, resistive	3 amps, resistive
<b>Soft Start Functions</b>					
Ramp times					
Start ramp	s	1–30	1–30	1–30	1–30
Stop ramp	s	0–30	0–30	0–30	0–30
Initial voltage % line voltage		30–92%	30–92%	30–92%	30–92%

**Dimensions**

Approximate Dimensions in Inches (mm)

**25–75 hp Models**

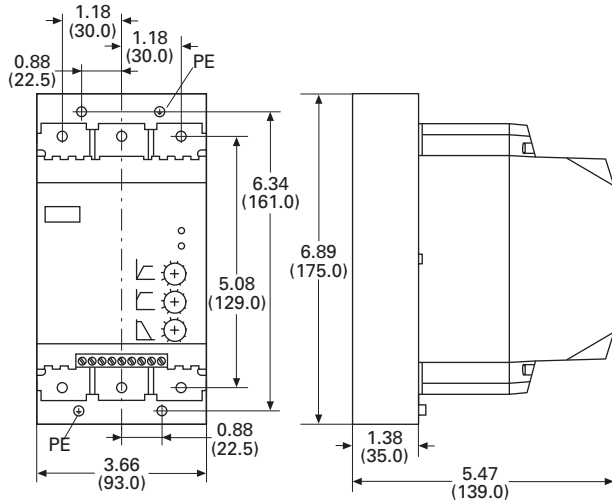

**100–150 hp Models**

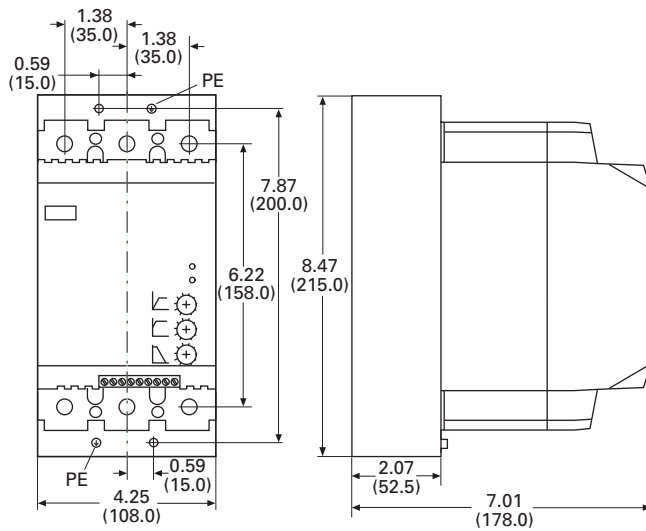

#### DS7 Soft Start Controllers



### DS7 Soft Start Controllers

#### Product Description

Eaton's DS7 line of reduced voltage solid-state soft start controllers is very compact, multi-functional, easy to install, and easy to commission. Designed to control the acceleration and deceleration of three-phase motors, the device is available for current ranges from 4–32A in four frame sizes.

#### Application Description

With its small size, it can easily fit in place of existing soft starters, wye-delta starters, or across-the-line NEMA® and IEC starters. This feature allows easy upgrades to existing systems. The product is designed to be wired in the three-phase line feeding the three motor input leads as is done for normal across-the-line starting. The starter uses silicon controlled rectifiers (SCRs) to ramp the voltage to the motor, providing smooth acceleration and deceleration of the load. After the motor is started, the internal run bypass relay closes, resulting in the motor running directly across-the-line. Internal run bypass significantly reduces the heat generated as compared to non-bypass starters. The soft stop option allows for a ramp stop time that may be longer than the coast-to-stop time. An external overload protection relay is needed.

### Contents

#### Description

	<i>Page</i>
Type S701, Soft Start Controllers .....	<b>V6-T35-3</b>
Type S701, Soft Start Controllers with Auxiliary Contact .....	<b>V6-T35-9</b>
Type S701, Soft Start Controllers with Brake .....	<b>V6-T35-12</b>
Type S511, Semiconductor Reversing Contactors .....	<b>V6-T35-15</b>
DS6 Soft Start Controllers .....	<b>V6-T35-19</b>
DS7 Soft Start Controllers	
Features and Benefits .....	<b>V6-T35-29</b>
Standards and Certifications .....	<b>V6-T35-29</b>
Instructional Leaflets .....	<b>V6-T35-29</b>
Product Selection .....	<b>V6-T35-30</b>
Technical Data and Specifications .....	<b>V6-T35-33</b>
Dimensions .....	<b>V6-T35-37</b>

#### Operation

##### Voltage Ramp Start

This start method provides a voltage ramp to the motor, resulting in a constant torque increase. This most commonly used form of soft start mode allows you to set the initial voltage value and the duration of the ramp to full voltage conditions.

- Adjustable initial voltage 30–92% of full voltage (120/230 Vac control voltage)
- Adjustable initial voltage 30–100% of full voltage (24 Vac/Vdc control voltage)
- Adjustable ramp time 1–30 seconds
- Bypass relays close at the end the ramp time (TOR)

##### Soft Stop

Allows for a controlled stopping of load. Used when a stop-time that is greater than the coast-to-stop time is desired. Often used with high friction loads where a sudden stop may cause system or product damage. Setting the soft stop time to a value of 0 turns off this feature.

- Soft stop time = 0–30 seconds

##### Start Ramp

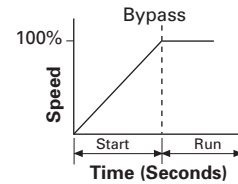

##### Stop Ramp

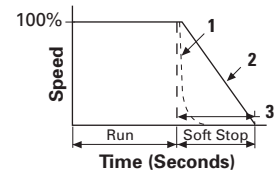

- 1 = Coast to Stop (Speed)
- 2 = Soft Stop Ramp (Voltage)
- 3 = Soft Stop Time

##### Auxiliary Contacts

Auxiliary contacts are provided to indicate soft start controller status.

##### Frame Size 1 (4A to 12A)—One Relay

The auxiliary relay indicates when the soft starter is at Top-of-Ramp (TOR).

##### Frame Size 2 (16A to 32A)—Two Relays

One auxiliary relay indicates when the soft starter is at Top-of-Ramp (TOR).

One auxiliary relay indicates that a RUN command is present, including start ramp, bypass, and stop ramp times.

**Features and Benefits**

- Run bypass mode greatly reduces internal heating created by the power dissipation across the SCRs. The bypass relay directly connects the motor to the line and improves system efficiency by reducing internal power losses
- Less heat minimizes enclosure size and cooling requirements, and maximizes the life of all devices in the enclosure
- LED displays device status and provides fault indication
- Variable ramp times and voltage control (torque control) settings provide unlimited starting configurations, allowing for maximum application flexibility
- Soft stop control suits applications where an abrupt stop of the load is not acceptable. Soft acceleration and deceleration reduces wear on belts, gears, chains, clutches, shafts, and bearings
- Minimizes the peak inrush current's stress on the power system. Peak starting torque can be managed to diminish mechanical system wear and damage.
- 24 Vac/Vdc control voltage enhances personnel and equipment safety. 120/230 Vac control voltage is also available
- Auxiliary relays indicate status of the soft start controllers
  - The TOR relay is active until motor stop command is received and/or the soft start controller detects a fault condition
  - RUN relay is active during the start ramp, bypass, and stop ramp

**Protective Features**

- Mains connection—The mains connection is monitored for a phase loss and/or undervoltage during ramp up
- Motor connection—The motor connection is monitored for an open condition during the ramp
- SCR faults—SCR performance is monitored during the ramp cycle for proper operation
- Heat sink over/under temperature—High ambient temperatures, extended ramp times, and high duty cycle conditions may cause the DS7 to exceed its thermal rating. When temperature goes under  $-5^{\circ}\text{C}$ , unit will trip as well. The DS7 is equipped with sensors that monitor the temperature of the device as well. The soft starter will trip in over/under temperature conditions, preventing device failure
- Warning is indicated for an over temperature condition for the next start
- Bypass relay
  - The DS7 can detect if the bypass relay fails to close after the ramp start or opens while the motor is running
  - The DS7 will also detect a condition whereas the bypass relay is closed when the RUN command is given
  - The DS7 will trip on a bypass dropout fault if either of these conditions occur

**Standards and Certifications**

- IEC 60947-4-2
- EN 60947-4-2
- UL® listed
- CSA certified
- CE marked
- C-Tick

**Instructional Leaflets**

- Instruction Leaflet IL03901001E

#### Product Selection

#### DS7 Soft Start Horsepower Ratings

Please refer to Application Note AP03901006E for additional information on proper size selection.

DS7 Soft Start Controller—Frame 1



#### DS7 Soft Start Controllers—Horsepower Ratings— 10 Second Ramp, One Start per Hour, 300% Current Limit at 40°C ①

Rated Current (A)	Motor Power (hp)			Maximum Allowable Breaker Size	Maximum Allowable Fuse Size	Recommended XTOB Overload (Direct Connect) ②	Recommended XTOE Overload ②	MMP ②	Connection Kit to MMP	Catalog Number
	200V	230V	480V							
3.7	0.75	0.75	2	HFD3015	15A Class RK5	XTOB004BC1	XTOE005BCS	XTPR004BC1	XTPAXTPCB	DS7-340SX004NO-N ④
										DS7-342SX004NO-N ⑤
6.9	1.5	2	3	HFD3015	15A Class RK5	XTOB006BC1 ①	XTOE020BCS	XTPR6P3BC1	XTPAXTPCB	DS7-340SX007NO-N ④
										DS7-342SX007NO-N ⑤
7.8	2	2	5	HFD3020	20A Class RK5	XTOB010BC1	XTOE020BCS	XTPR010BC1	XTPAXTPCB	DS7-340SX009NO-N ④
										DS7-342SX009NO-N ⑤
11	3	3	7.5	HFD3030	20A Class RK5	XTOB012BC1	XTOE020BCS	XTPR012BC1	XTPAXTPCB	DS7-340SX012NO-N ④
										DS7-342SX012NO-N ⑤
15.2	3	5	10	HFD3035	25A Class RK5	XTOB016CC1	XTOE020CCS	XTPR016BC1	XTPAXTPCC	DS7-340SX016NO-N ④
										DS7-342SX016NO-N ⑤
22	5	7.5	15	HFD3060	40A Class RK5	XTOB024CC1	XTOE045CCS	XTPR025BC1	XTPAXTPCC	DS7-340SX024NO-N ④
										DS7-342SX024NO-N ⑤
32	7.5	10	20	HFD3070	50A Class RK5	XTOB032CC1	XTOE045CCS	XTPR032BC1	XTPAXTPCC	DS7-340SX032NO-N ④
										DS7-342SX032NO-N ⑤

DS7 Soft Start Controller—Frame 1



#### DS7 Soft Start Controllers—Horsepower Ratings— 10 Second Ramp, One Start per Hour, 400% Current Limit at 40°C ①

Rated Current (A)	Motor Power (hp)			Maximum Allowable Breaker Size	Maximum Allowable Fuse Size	Recommended XTOB Overload (Direct Connect) ②	Recommended XTOE Overload ②	MMP ②	Connection Kit to MMP	Catalog Number
	200V	230V	480V							
3	0.5	0.5	1.5	HFD3015	15A Class RK5	XTOB004BC1	XTOE005BCS	XTPR004BC1	XTPAXTPCB	DS7-340SX004NO-N ④
										DS7-342SX004NO-N ⑤
4.8	1	1	3	HFD3015	15A Class RK5	XTOB006BC1 ①	XTOE020BCS	XTPR6P3BC1	XTPAXTPCB	DS7-340SX007NO-N ④
										DS7-342SX007NO-N ⑤
6.9	1.5	2	3	HFD3020	20A Class RK5	XTOB006BC1	XTOE020BCS	XTPR6P3BC1	XTPAXTPCB	DS7-340SX009NO-N ④
										DS7-342SX009NO-N ⑤
9	2	2	5	HFD3030	20A Class RK5	XTOB010BC1	XTOE020BCS	XTPR010BC1	XTPAXTPCB	DS7-340SX012NO-N ④
										DS7-342SX012NO-N ⑤
11	3	3	7.5	HFD3035	25A Class RK5	XTOB016CC1	XTOE020CCS	XTPR016BC1	XTPAXTPCC	DS7-340SX016NO-N ④
										DS7-342SX016NO-N ⑤
17.5	5	5	10	HFD3060	40A Class RK5	XTOB016CC1	XTOE045CCS	XTPR016BC1	XTPAXTPCC	DS7-340SX024NO-N ④
										DS7-342SX024NO-N ⑤
22	5	7.5	15	HFD3070	50A Class RK5	XTOB024CC1	XTOE045CCS	XTPR025BC1	XTPAXTPCC	DS7-340SX032NO-N ④
										DS7-342SX032NO-N ⑤

**Notes**

- ① Actual motor FLAs vary. Verify these devices cover the motor specific FLA.
- ② Selections are based on motor FLA value at 480V.
- ③ Not to be used with 230V.
- ④ 24 Vac/Vdc device.
- ⑤ 120/230 Vac device.

### DS7 Soft Start kW Ratings

Please refer to Application Note AP03901006E for additional information on proper size selection.

DS7 Soft Start Controller—Frame 2



#### DS7 Soft Start Controllers—kW Ratings According to IEC 60947-4-2—10 Second Ramp, One Start per Hour, 300% Current Limit at 40°C ①

Rated Current (A)	Motor Power (kW)		Maximum Allowable Breaker Size	Maximum Allowable Fuse Size	Recommended XTOB Overload (Direct Connect) ②	Recommended XTOE Overload ②	MMP ②	Connection Kit to MMP	Catalog Number
	230V	400V							
3.8	0.75	1.5	HFD3015	15A Class RK5	XTOB004BC1	XTOE005BCS	XTPR004BC1	XTPAXTPCB	DS7-340SX004NO-N ④ DS7-342SX004NO-N ⑤
7	1.5	3	HFD3015	15A Class RK5	XTOB006BC1 ①	XTOE020BCS	XTPR6P3BC1	XTPAXTPCB	DS7-340SX007NO-N ④ DS7-342SX007NO-N ⑤
9	2.2	4	HFD3020	20A Class RK5	XTOB010BC1	XTOE020BCS	XTPR010BC1	XTPAXTPCB	DS7-340SX009NO-N ④ DS7-342SX009NO-N ⑤
12	3	5.5	HFD3030	20A Class RK5	XTOB012BC1	XTOE020BCS	XTPR012BC1	XTPAXTPCB	DS7-340SX012NO-N ④ DS7-342SX012NO-N ⑤
16	4	7.5	HFD3035	25A Class RK5	XTOB016CC1	XTOE020CCS	XTPR016BC1	XTPAXTPCC	DS7-340SX016NO-N ④ DS7-342SX016NO-N ⑤
24	5.5	11	HFD3060	40A Class RK5	XTOB024CC1	XTOE045CCS	XTPR025BC1	XTPAXTPCC	DS7-340SX024NO-N ④ DS7-342SX024NO-N ⑤
32	7.5	15	HFD3070	50A Class RK5	XTOB032CC1	XTOE045CCS	XTPR032BC1	XTPAXTPCC	DS7-340SX032NO-N ④ DS7-342SX032NO-N ⑤

DS7 Soft Start Controller—Frame 2



#### DS7 Soft Start Controllers—kW Ratings According to IEC 60947-4-2—10 Second Ramp, One Start per Hour, 400% Current Limit at 40°C ①

Rated Current (A)	Motor Power (kW)		Maximum Allowable Breaker Size	Maximum Allowable Fuse Size	Recommended XTOB Overload (Direct Connect) ②	Recommended XTOE Overload ②	MMP ②	Connection Kit to MMP	Catalog Number
	230V	400V							
2.5	0.33	1	HFD3015	15A Class RK5	XTOB004BC1	XTOE005BCS	XTPR004BC1	XTPAXTPCB	DS7-340SX004NO-N ④ DS7-342SX004NO-N ⑤
3.8	0.75	1.5	HFD3015	15A Class RK5	XTOB006BC1 ①	XTOE020BCS	XTPR6P3BC1	XTPAXTPCB	DS7-340SX007NO-N ④ DS7-342SX007NO-N ⑤
7	1.5	3	HFD3020	20A Class RK5	XTOB006BC1	XTOE020BCS	XTPR6P3BC1	XTPAXTPCB	DS7-340SX009NO-N ④ DS7-342SX009NO-N ⑤
9	2.2	4	HFD3030	20A Class RK5	XTOB010BC1	XTOE020BCS	XTPR010BC1	XTPAXTPCB	DS7-340SX012NO-N ④ DS7-342SX012NO-N ⑤
12	3	5.5	HFD3035	25A Class RK5	XTOB016CC1	XTOE020CCS	XTPR016BC1	XTPAXTPCC	DS7-340SX016NO-N ④ DS7-342SX016NO-N ⑤
16	4	7.5	HFD3060	40A Class RK5	XTOB016CC1	XTOE045CCS	XTPR016BC1	XTPAXTPCC	DS7-340SX024NO-N ④ DS7-342SX024NO-N ⑤
24	5.5	11	HFD3070	50A Class RK5	XTOB024CC1	XTOE045CCS	XTPR025BC1	XTPAXTPCC	DS7-340SX032NO-N ④ DS7-342SX032NO-N ⑤

**Notes**

- ① Actual motor FLAs vary. Verify these devices cover the motor specific FLA.
- ② Selections are based on motor FLA value at 480V.
- ③ Not to be used with 230V.
- ④ 24 Vac/Vdc device.
- ⑤ 120/230 Vac device.

**Considerations**

1. Either XTOB or XTOE or equivalent overload protection devices may be selected. In addition, manual motor protectors—MMP series can also be considered.
2. Isolation contactor is required for mains isolation.

**24 Vdc Control Power**

Eaton's ELC power supplies are recommended as a compact and low-cost source for 24 Vdc power. The light-weight, DIN rail mounted devices have a wide input voltage range and robust screw terminals make these power supplies easy to install and use. These power supplies are available in 1A and 2A models.

**AC Control Power**

24, 120, or 230 volts AC may be used for control power in accordance with the model requirements.

**DC Power Supply Selection**

Description	Catalog Number
85–264V input and 24V output	<b>ELC-PS01</b>
380–480V input and 24V output	<b>PSS25F</b>



## Technical Data and Specifications

## DS7 Soft Start Controllers

## Rated Control Circuit

Voltage 24 Vac/Vdc Voltage 110/230 Vac	Unit	DS7-340SX004NO-N DS7-342SX004NO-N	DS7-340SX007NO-N DS7-342SX007NO-N	DS7-340SX009NO-N DS7-342SX009NO-N	DS7-340SX012NO-N DS7-342SX012NO-N
---	------	--------------------------------------	--------------------------------------	--------------------------------------	--------------------------------------

## General

Standards		IEC/EN 60947-4-2; GB14048.6; UL508; CSA-C22.2 No 0-M91; CSA-C22.2 No 14-05 CE marking	IEC/EN 60947-4-2; GB14048.6; UL508; CSA-C22.2 No 0-M91; CSA-C22.2 No 14-05 CE marking	IEC/EN 60947-4-2; GB14048.6; UL508; CSA-C22.2 No 0-M91; CSA-C22.2 No 14-05 CE marking	IEC/EN 60947-4-2; GB14048.6; UL508; CSA-C22.2 No 0-M91; CSA-C22.2 No 14-05 CE marking
Certifications/markings		UL/CE/CSA/C-Tick	UL/CE/CSA/C-Tick	UL/CE/CSA/C-Tick	UL/CE/CSA/C-Tick
Ambient temperature (operation)	°C	0 to 40°C, above 40°C de-rate linearly by 1% of rated current per Celcius to 60°C	0 to 40°C, above 40°C de-rate linearly by 1% of rated current per Celcius to 60°C	0 to 40°C, above 40°C de-rate linearly by 1% of rated current per Celcius to 60°C	0 to 40°C, above 40°C de-rate linearly by 1% of rated current per Celcius to 60°C
Ambient temperature (storage)	°C	-25 to 55°C	-25 to 55°C	-25 to 55°C	-25 to 55°C
Altitude		0-1000m, above 1000m de-rate linearly by 2.5% of rated current per 100m to a maximum of 2000m	0-1000m, above 1000m de-rate linearly by 2.5% of rated current per 100m to a maximum of 2000m	0-1000m, above 1000m de-rate linearly by 2.5% of rated current per 100m to a maximum of 2000m	0-1000m, above 1000m de-rate linearly by 2.5% of rated current per 100m to a maximum of 2000m
Installation		Vertical	Vertical	Vertical	Vertical
Protection class		IP20	IP20	IP20	IP20
Protection class applies to the front and operator control and display elements. Protection type from all sides is IP00.		With optional covers from the NZM range, protection type IP40 from all sides can be achieved	With optional covers from the NZM range, protection type IP40 from all sides can be achieved	With optional covers from the NZM range, protection type IP40 from all sides can be achieved	With optional covers from the NZM range, protection type IP40 from all sides can be achieved
Busbar tag shroud		Back of hand and finger-proof (from front face)	Back of hand and finger-proof (from front face)	Back of hand and finger-proof (from front face)	Back of hand and finger-proof (from front face)
Overvoltage category/pollution degree		II/2	II/2	II/2	II/2
Shock resistance		8g/11ms	8g/11ms	8g/11ms	8g/11ms
Vibration resistance according to EN 60721-3-2		2M2	2M2	2M2	2M2
Mean heat dissipation at rated duty cycle	W	0.2	0.35	0.35	0.6
Radio interference		B	B	B	B
Dimensions (W x H x D)	mm	45 x 130 x 95	45 x 130 x 95	45 x 130 x 95	45 x 130 x 95
	in	1.77 x 5.12 x 3.74	1.77 x 5.12 x 3.74	1.77 x 5.12 x 3.74	1.77 x 5.12 x 3.74
Weight	kg	0.35	0.35	0.35	0.35
	lb	0.77	0.77	0.77	0.77

## Main Circuit

Rated operational voltage	V	230-460 Vac	230-460 Vac	230-460 Vac	230-460 Vac
Mains frequency	Hz	50/60 Hz	50/60 Hz	50/60 Hz	50/60 Hz
Rated operation current AC 53	I <sub>e</sub>	4	7	9	12

## Motor Power Ratings

200V	hp	0.75	1.5	2	3
230V	hp	0.75	2	2	5
480V	hp	2	3	5	10
230V	kW	0.75	1.5	2.2	3
400V	kW	1.5	3	4	5.5
Overload cycle according to EN 60947-4-2		4A: AC53a; 3-5; 75-10	7A: AC53a; 3-5; 75-10	9A: AC53a; 3-5; 75-10	12A: AC53a; 3-5; 75-10

## DS7 Soft Start Controllers, continued

## Rated Control Circuit

Voltage 24 Vac/Vdc Voltage 110/230 Vac	Unit	DS7-340SX004NO-N DS7-342SX004NO-N	DS7-340SX007NO-N DS7-342SX007NO-N	DS7-340SX009NO-N DS7-342SX009NO-N	DS7-340SX012NO-N DS7-342SX012NO-N
---	------	--------------------------------------	--------------------------------------	--------------------------------------	--------------------------------------

## Wire Specifications

Power terminals					
Single conductor—solid or stranded	AWG	18–10	18–10	18–10	18–10
Terminal torque	lb-in	11	11	11	11
Control signals					
Single conductor—solid or stranded	AWG	18–10	18–10	18–10	18–10
Terminal torque	lb-in	11	11	11	11

## Power Section

Rated impulse withstand voltage	$U_{imp}$ 1.2/ 50_s	4 kV	4 kV	4 kV	4 kV
Rated insulation voltage		500	500	500	500

## Control Commands—Vac/Vdc

Supply voltage control board $U_s$ nominal	Vdc	20.4–26.4	20.4–26.4	20.4–26.4	20.4–26.4
Current consumption at 24 Vac/Vdc	mA	1.6	1.6	1.6	1.6
Pick-up voltage		+17.3–+27	+17.3–+27	+17.3–+27	+17.3–+27
Drop-out voltage		+3–0	+3–0	+3–0	+3–0

## Relay Outputs

Number of relays		1 (TOR)	1 (TOR)	1 (TOR)	1 (TOR)
Maximum voltage	Vac	250	250	250	250
Maximum current	A	1A	1A	1A	1A

## Soft Start Functions

Ramp times					
Start ramp	s	1–30	1–30	1–30	1–30
Stop ramp	s	0–30	0–30	0–30	0–30
Initial voltage % line voltage		30–100%	30–100%	30–100%	30–100%

## Control Commands—Vac

Supply voltage control board $U_s$ nominal	Vac	102–253	102–253	102–253	102–253
Current consumption at 24 Vac/Vdc	mA	4	4	4	4
Pick-up voltage	Vac	102–230	102–230	102–230	102–230
Drop-out voltage	Vac	0–28	0–28	0–28	0–28

## Relay Outputs

Number of relays		1 (TOR)	1 (TOR)	1 (TOR)	1 (TOR)
Maximum voltage	Vac	250	250	250	250
Maximum current	A	3A	3A	3A	3A

## Soft Start Functions

Ramp times					
Start ramp	s	1–30	1–30	1–30	1–30
Stop ramp	s	0–30	0–30	0–30	0–30
Initial voltage % line voltage		30–92%	30–92%	30–92%	30–92%

## DS7 Soft Start Controllers, continued

Rated Control Circuit			DS7-340SX016NO-N DS7-342SX016NO-N	DS7-340SX024NO-N DS7-342SX024NO-N	DS7-340SX032NO-N DS7-342SX032NO-N
Voltage 24 Vac/Vdc Voltage 110/230 Vac	Unit				
<b>General</b>					
Standards			IEC/EN 60947-4-2; GB14048.6; UL508; CSA-C22.2 No 0-M91; CSA-C22.2 No 14-05 CE marking	IEC/EN 60947-4-2; GB14048.6; UL508; CSA-C22.2 No 0-M91; CSA-C22.2 No 14-05 CE marking	IEC/EN 60947-4-2; GB14048.6; UL508; CSA-C22.2 No 0-M91; CSA-C22.2 No 14-05 CE marking
Certifications/markings			UL/CE/CSA/C-Tick	UL/CE/CSA/C-Tick	UL/CE/CSA/C-Tick
Ambient temperature (operation)	°C		0 to 40°C, above 40°C de-rate linearly by 1% of rated current per Celcius to 60°C	0 to 40°C, above 40°C de-rate linearly by 1% of rated current per Celcius to 60°C	0 to 40°C, above 40°C de-rate linearly by 1% of rated current per Celcius to 60°C
Ambient temperature (storage)	°C		-25 to 55°C	-25 to 55°C	-25 to 55°C
Altitude			0–1000m, above 1000m de-rate linearly by 2.5% of rated current per 100m to a maximum of 2000m	0–1000m, above 1000m de-rate linearly by 2.5% of rated current per 100m to a maximum of 2000m	0–1000m, above 1000m de-rate linearly by 2.5% of rated current per 100m to a maximum of 2000m
Installation			Vertical	Vertical	Vertical
Protection class			IP20	IP20	IP20
Protection class applies to the front and operator control and display elements. Protection type from all sides is IP00.			With optional covers from the NZM range, protection type IP40 from all sides can be achieved	With optional covers from the NZM range, protection type IP40 from all sides can be achieved	With optional covers from the NZM range, protection type IP40 from all sides can be achieved
Busbar tag shroud			Back of hand and finger-proof (from front face)	Back of hand and finger-proof (from front face)	Back of hand and finger-proof (from front face)
Overvoltage category/ pollution degree			II/2	II/2	II/2
Shock resistance			8g/11ms	8g/11ms	8g/11ms
Vibration resistance according to EN 60721-3-2			2M2	2M2	2M2
Mean heat dissipation at rated duty cycle	W		0.8	1.1	1.5
Radio interference			B	B	B
Dimensions (W x H x D)	mm		45 x 150 x 118	45 x 150 x 118	45 x 150 x 118
	in		1.77 x 5.12 x 3.74	1.77 x 5.12 x 3.74	1.77 x 5.12 x 3.74
Weight	kg		0.4	0.4	0.4
	lb		0.88	0.88	0.88
<b>Main Circuit</b>					
Rated operational voltage	V		230–460 Vac	230–460 Vac	230–460 Vac
Mains frequency	Hz		50/60 Hz	50/60 Hz	50/60 Hz
Rated operation current AC 53	I <sub>e</sub>		16	24	32
<b>Motor Power Ratings</b>					
200V	hp		3	5	10
230V	hp		5	7.5	10
480V	hp		10	15	25
230V	kW		4	5.5	7.5
400V	kW		7.5	11	15
Overload cycle according to EN 60947-4-2			16A: AC53a; 3-5; 75-10	24A: AC53a; 3-5; 75-10	32A: AC53a; 3-5; 75-10

## DS7 Soft Start Controllers, continued

Rated Control Circuit			DS7-340SX016NO-N	DS7-340SX024NO-N	DS7-340SX032NO-N
Voltage 24 Vac/Vdc	Unit	DS7-342SX016NO-N	DS7-342SX024NO-N	DS7-342SX032NO-N	
Voltage 110/230 Vac					
<b>Wire Specifications</b>					
Power terminals					
Single conductor—solid or stranded	AWG	18–6	18–6	18–6	18–6
Terminal torque	lb-in	11	11	11	11
Control Signals					
Single conductor—solid or stranded	AWG	18–10	18–10	18–10	18–10
Terminal torque	lb-in	11	11	11	11
<b>Power Section</b>					
Rated impulse withstand voltage	$U_{imp}$ 1.2/ 50_s	4 kV	4 kV	4 kV	4 kV
Rated insulation voltage		500	500	500	500
<b>Control Commands—Vac/Vdc</b>					
Supply voltage control board $U_s$ nominal	Vdc	20.4–26.4	20.4–26.4	20.4–26.4	20.4–26.4
Current consumption at 24 Vac/Vdc	mA	1.6	1.6	1.6	1.6
Pick-up voltage		+17.3–+27	+17.3–+27	+17.3–+27	+17.3–+27
Drop-out voltage		+3–0	+3–0	+3–0	+3–0
<b>Relay Outputs</b>					
Number of relays		2 (TOR, Ready)	2 (TOR, Ready)	2 (TOR, Ready)	2 (TOR, Ready)
Maximum voltage	Vac	250	250	250	250
Maximum current	A	1A	1A	1A	1A
<b>Soft Start Functions</b>					
Ramp times					
Start ramp	s	1–30	1–30	1–30	1–30
Stop ramp	s	0–30	0–30	0–30	0–30
Initial voltage % line voltage		30–100%	30–100%	30–100%	30–100%
<b>Control Commands—Vac</b>					
Supply voltage control board $U_s$ nominal	Vac	102–253	102–253	102–253	102–253
Current consumption at 102–253 Vac	mA	4	4	4	4
Pick-up voltage	Vac	102–230	102–230	102–230	102–230
Drop-out voltage	Vac	0–28	0–28	0–28	0–28
<b>Relay Outputs</b>					
Number of relays		2 (TOR, Run)	2 (TOR, Run)	2 (TOR, Run)	2 (TOR, Run)
Maximum voltage	Vac	250	250	250	250
Maximum current	A	3A	3A	3A	3A
<b>Soft Start Functions</b>					
Ramp times					
Start ramp	s	1–30	1–30	1–30	1–30
Stop ramp	s	0–30	0–30	0–30	0–30
Initial voltage % line voltage		30–92%	30–92%	30–92%	30–92%

**Dimensions**

Approximate Dimensions in Inches (mm)

**Frame Size 1**

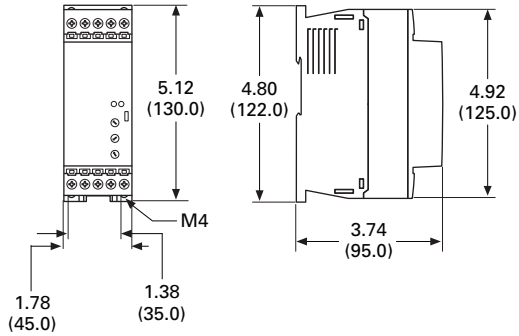

**Catalog Numbers**

DS7-340SX004N0-N	DS7-342SX004N0-N
DS7-340SX007N0-N	DS7-342SX007N0-N
DS7-340SX009N0-N	DS7-342SX009N0-N
DS7-340SX012N0-N	DS7-342SX012N0-N

**Frame Size 2**

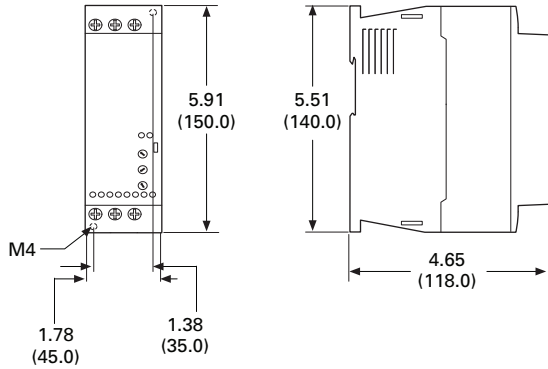

**Catalog Numbers**

DS7-340SX016N0-N	DS7-342SX016N0-N
DS7-340SX024N0-N	DS7-342SX024N0-N
DS7-340SX032N0-N	DS7-342SX032N0-N

Solid-State Starters



### Contents

**Description**

**Page**

Solid-State Starters	
Type S801, Intelligent Technologies (IT.) Soft Starters .....	<b>V6-T35-39</b>
Type S811, Intelligent Technologies (IT.) Soft Starters with DIM .....	<b>V6-T35-67</b>

### Product Overview

#### Type S801

Eaton’s Intelligent Technologies (IT.) S801 line of reduced voltage soft starters is very compact, multi-functional, easy to install and easy to program. Designed to control acceleration and deceleration of three-phase motors, the line is available for current ranges from 11A all the way through 1000A applications, and is suitable for mounting in motor control centers or in enclosed control (NEMA 1, 4, 4X and 12) applications.

#### Type S811

Eaton’s IT. S811 offers all the popular features of the S801, but adds enhanced functionality with the new DIM (Digital Interface Module), communications, metering, monitoring and diagnostics capabilities.

Eaton’s Intelligent Technologies (IT.) Line of S811 Reduced Voltage Soft Starters is very compact, multi-functional, easy to install and easy to set operating parameters. Designed to control the acceleration and deceleration of three-phase motors up to 690V, the line is available from 11–1000A.

The S811 is designed to be a complete package combining the silicon controlled rectifiers (SCRs), bypass contactor and overload in one, very compact unit. The S811 is available as a component for panel mounting, in motor control centers or in enclosed control (NEMA Type 1, 3R, 4, 4X, 7/9 and 12).

Type S801, Intelligent Technologies (IT.) Soft Starters



**Contents**

<i><b>Description</b></i>	<i><b>Page</b></i>
Type S801, Intelligent Technologies (IT.) Soft Starters	
Operation . . . . .	<b>V6-T35-40</b>
Features . . . . .	<b>V6-T35-42</b>
Benefits . . . . .	<b>V6-T35-42</b>
Standards and Certifications . . . . .	<b>V6-T35-42</b>
Catalog Number Selection . . . . .	<b>V6-T35-42</b>
Product Selection . . . . .	<b>V6-T35-43</b>
Accessories . . . . .	<b>V6-T35-57</b>
Options . . . . .	<b>V6-T35-58</b>
Technical Data and Specifications . . . . .	<b>V6-T35-59</b>
Wiring Diagrams . . . . .	<b>V6-T35-63</b>
Dimensions . . . . .	<b>V6-T35-64</b>
Type S811, Intelligent Technologies (IT.) Soft Starters with DIM . . . . .	<b>V6-T35-67</b>

**Type S801, Intelligent Technologies (IT.) Soft Starters**

**Product Description**

Eaton’s Intelligent Technologies (IT.) S801 line of reduced voltage soft starters is very compact, multi-functional, easy to install and easy to program. Designed to control acceleration and deceleration of three-phase motors, the line is available for current ranges from 11A all the way through 1000A applications, and is suitable for mounting in motor control centers or in enclosed control (NEMA 1, 4, 4X and 12) applications.

**Application Description**

The S801 line of IT. Soft Starters is designed to be the smallest, most compact soft starter in the market today. With this small size, it can easily fit in place of existing soft starter designs, wye-delta starters or across-the-line NEMA and IEC starters. This feature allows easy retrofits of existing motor control centers or enclosures, and saves the expense of replacing existing structure or adding a new one to house a soft starter.

The product is designed to work with three-phase motors in a delta (three-lead) configuration. The S801 works with all motors from fractional horsepower up to motors requiring 1000A of steady-state current. The built-in overload (in ranges from 11–1000A) and run bypass contactor make installation and setup quick and easy. The overload also offers some advanced protective functions to give additional motor protection.

With the pump control option, it is the No. 1 soft starter available for pumping applications. This unique soft stopping control provides a smooth transition for stopping a motor and eliminates the “water-hammer” effect that can damage pipes, valves and pumps.

#### Operation

##### Overload Functionality

###### Overtemperature

Protects the device from overheating. Starter will shut down at 100°C.

###### Stall

Selectable protective feature, unit trips to protect system in event motor can not get to rated speed in the defined ramp period.

###### Jam

Selectable protective feature, unit trips to prevent damage to motor during normal run.

###### Phase Loss

Selectable protective feature, trips under voltage loss condition to any phase.

###### Phase Reversal

Selectable protective feature, trips when phase rotation is something other than A-B-C.

###### Kick Start

Selectable feature that provides a current "kick" of up to 550% of full load current for 0 to 2.0 seconds. This provides the additional torque required at startup to break free a motor.

###### Ramp Start

Provides a constant increase in torque to the motor.

###### Current Limit Start

Limits the maximum current available to the motor during the startup phase.

###### Soft Stop

Allows for a controlled stopping of a frictional load.

###### Shorted SCR Detection

Monitors for shorted SCR in the power polls.

#### Starting Characteristics

##### Kick Start

Provides an initial boost of current to the motor to help break free the rotor and start spinning the motor.

- 0–85% of locked rotor torque
- 0–2.0 seconds duration

#### Starting Characteristics—Kick Start

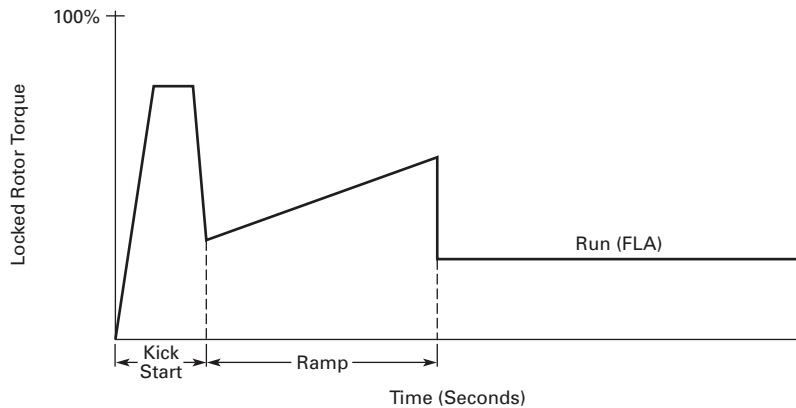

##### Ramp Start

The most commonly used form of soft start. This allows you to set the initial torque value (of the ramp) and then raises it to full voltage conditions.

- Adjustable initial torque = 0–85% of locked rotor torque
- Adjustable ramp time = 0.5–180 seconds (can be extended with factory modification)

#### Starting Characteristics—Ramp Start

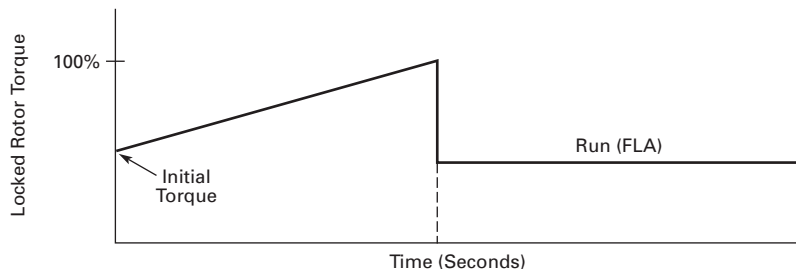



### Current Limit

This mode of soft starting is used when it becomes necessary to limit the maximum starting current due to long start times or to protect the motor.

- Maximum current of 0–85% locked rotor current
- Adjustable ramp time = 0.5–180 seconds and can be extended to 360 seconds as a factory installed option

### Starting Characteristics—Current Limit

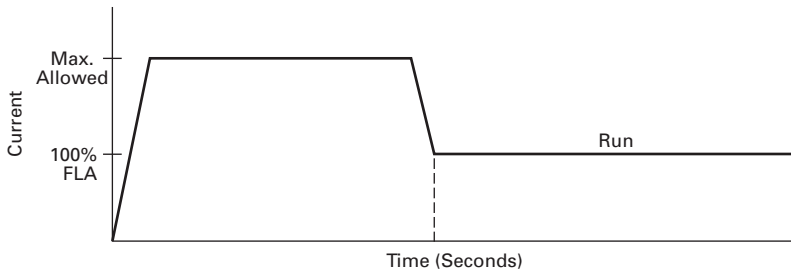

### Soft Stop

Used when an extended coast-to-rest period is desired. Often used with high friction loads where a sudden stop may cause system or product damage.

- Stop time = 0–60 seconds

### Starting Characteristics—Soft Stop

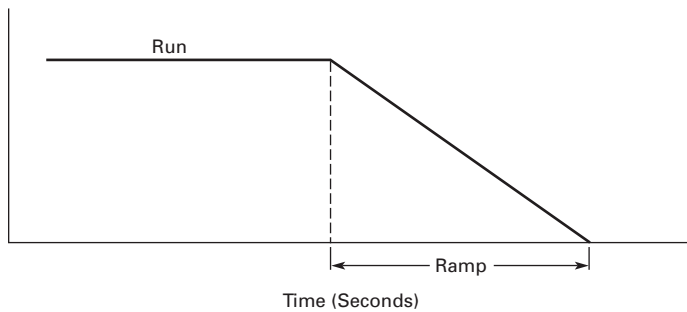

# 35.2

## Reduced Voltage Motor Starters

### Solid-State Starters

35

#### Features

- Built-in overload protection
- Built-in run bypass contactor
- Adjustable ramp times
- Adjustable torque control
- Adjustable kick start control
- Programmable overload settings, 31–100% (3.2:1) of rated current for the unit
- Physically fits in place of most NEMA and IEC starters
- Easy to use control interface module
- Soft stop control
- Multiple trip class settings (5, 10, 20 and 30)
- Six SCR control
- Optional pump control
- Optional extended ramp time
- Optional CIM door mount kit for safety
- Optional IP20 protection
- Optional Inside-the-delta mode

#### Benefits

- Reduced wear on belts, gears, chains, clutches, shafts and bearings
- Allows for controlling the inrush current to the motor
- Reduced inrush current leads to more stable power grid and can lower peak demand charges
- Elimination of water-hammer in pumping applications
- Less shock to product on conveyor lines and material handling gear
- 24 Vdc control enhances personnel and equipment safety

#### Standards and Certifications

- IEC 947 compliant
- EN 60947-4-2
- CSA certification
- cULus listed (File No. E202571)
- CE marked



#### User Manuals

A comprehensive user manual is available and can be downloaded free of charge from [www.eaton.com](http://www.eaton.com) by performing a document search for MN03902008E.

The Inside-the-Delta User Manual can be found by searching for Pub. No. MN03902009E.

#### Catalog Number Selection

##### S801 Open Soft Starters <sup>①②</sup>

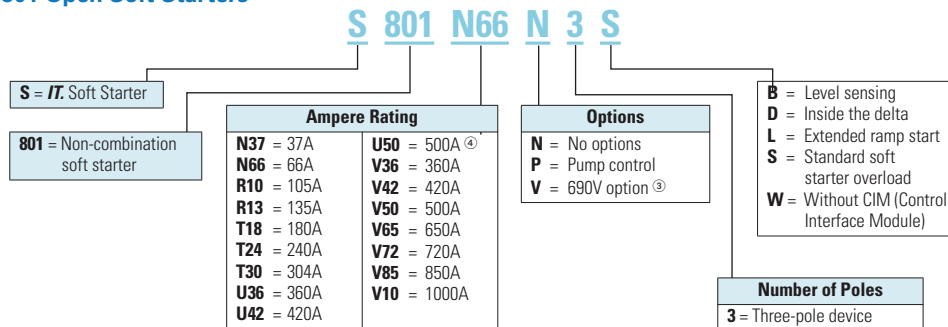

#### Notes

- ① T, U- and V-Frames require lug kits found on **Page V6-T35-57**.
- ② All units require a 24 Vdc power supply found on catalog **Page V6-T35-57**, or equivalent.
- ③ 690V is available only from T18 thru V85. Not available on U-Frames.
- ④ U-Frame 500A unit does not have IEC certification.

### Product Selection

#### Standard Duty Ratings

The table below is the base ratings for the **IT** Soft Starter. The tables included in this catalog are meant to be a selection table for different applications, but to match a unit to your exact application, consult with your local Eaton representative or call our Technical Resource Center.

#### Standard Duty Ratings

Starting Method	Ramp Current % of FLA	Ramp Time Seconds	Starts per Hour	Ambient Temperature
Soft start	300%	30 sec.	3	50°C
Full voltage	500%	10 sec.	3	50°C
Wye-delta	350%	20 sec.	3	50°C
80% RVAT	480%	20 sec.	2	50°C
65% RVAT	390%	20 sec.	3	50°C
50% RVAT	300%	20 sec.	4	50°C

Motor applications and customer needs come in many different varieties. With the standard and severe duty rating tables, we have attempted to provide

guidelines on what the **IT** Soft Starter is capable of. If the application falls under these categories, you can use these charts. For other applications, or when a

question arises, consult with your local Eaton representative or call our Technical Resource Center.

#### S801



#### Standard Duty—15 Second Ramp, 4 Starts per Hour, 300% Current Limit at 40°C

Max. Current	Three-Phase Motors kW Rating (50 Hz)			hp Rating (60 Hz)						575–690V <sup>①</sup>		Catalog Number <sup>②③</sup>
	230V	380–400V	440V	200V 1.0SF	1.15SF	230V 1.0SF	1.15SF	460V 1.0SF	1.15SF	1.0SF	1.15SF	
<b>Frame Size N</b>												
37	10	18.5	18.5	10	10	10	10	25	20	30	30	<b>S801N37N3S</b>
66	18.5	30	37	20	15	20	20	50	40	60	50	<b>S801N66N3S</b>
<b>Frame Size R</b>												
105	30	55	59	30	25	40	30	75	60	100	75	<b>S801R10N3S</b>
135	40	63	80	40	30	50	40	100	75	125	100	<b>S801R13N3S</b>
<b>Frame Size T</b>												
180	51	90	110	60	50	60	60	150	125	150	150	<b>S801T18N3S</b>
240	75	110	147	75	60	75	75	200	150	200	200	<b>S801T24N3S</b>
304	90	160	185	100	75	100	100	250	200	300	250	<b>S801T30N3S</b>
<b>Frame Size U</b>												
360	110	185	220	125	100	150	125	300	250	350	300	<b>S801U36N3S</b>
420	129	220	257	150	125	175	150	350	300	450	350	<b>S801U42N3S</b>
500	150	257	300	150	150	200	150	400	350	500	450	<b>S801U50N3S<sup>④</sup></b>
<b>Frame Size V</b>												
360	110	185	220	125	100	150	125	300	250	350	300	<b>S801V36N3S</b>
420	129	220	257	150	125	175	150	350	300	450	350	<b>S801V42N3S</b>
500	150	257	300	150	150	200	150	400	350	500	450	<b>S801V50N3S</b>
650	200	355	425	250	200	250	200	500	450	600	500	<b>S801V65N3S</b>
720	220	400	450	—	—	300	250	600	500	700	600	<b>S801V72N3S</b>
850	257	475	500	—	—	350	300	700	600	900	700	<b>S801V85N3S</b>
1000	277	525	550	—	—	400	350	800	700	900	800	<b>S801V10N3S<sup>⑤</sup></b>

For **Pump Option**, replace character **8** with **"P"** and also, see **Page V6-T35-58**.

#### Notes

- ① 690V is available only from T18 thru V85. Not available on U-Frames.
- ② For a longer ramp acceleration time of 0.5 to 360 seconds, see **Page V6-T35-58**.
- ③ For two-wire (level sensing) control, change the last digit from **S** to **B**.
- ④ U-Frame 500A does not have IEC certification.
- ⑤ For more information on optimum performance of the 1000A Frame Size V S801, see Appendix C of MN03902008E.

S801



#### Standard Duty—25 Second Ramp, 4 Starts per Hour, 300% Current Limit at 40°C

Max. Current	Three-Phase Motors kW Rating (50 Hz)			hp Rating (60 Hz)				575–690V <sup>①</sup>				Catalog Number <sup>②③</sup>
	230V	380–400V	440V	200V 1.0SF	1.15SF	230V 1.0SF	1.15SF	460V 1.0SF	1.15SF	1.0SF	1.15SF	
<b>Frame Size N</b>												
34	9	15	18.5	10	7-1/2	10	10	25	20	30	25	<b>S801N37N3S</b>
63	15	30	33	20	15	20	20	40	40	60	50	<b>S801N66N3S</b>
<b>Frame Size R</b>												
96	25	45	55	30	25	30	30	75	60	75	75	<b>S801R10N3S</b>
120	33	63	63	40	30	40	40	75	75	100	100	<b>S801R13N3S</b>
<b>Frame Size T</b>												
150	45	80	90	50	40	50	50	100	100	150	125	<b>S801T18N3S</b>
215	63	110	132	60	60	75	60	150	150	200	150	<b>S801T24N3S</b>
278	80	147	160	75	75	100	75	200	200	250	250	<b>S801T30N3S</b>
<b>Frame Size U</b>												
320	90	160	185	100	75	125	100	250	200	300	250	<b>S801U36N3S</b>
380	110	200	220	125	100	150	125	300	250	350	300	<b>S801U42N3S</b>
460	140	250	280	150	125	150	150	350	300	450	400	<b>S801U50N3S<sup>④</sup></b>
<b>Frame Size V</b>												
320	90	160	185	100	75	125	100	250	200	300	250	<b>S801V36N3S</b>
380	110	200	220	125	100	150	125	300	250	350	300	<b>S801V42N3S</b>
460	140	250	280	150	125	150	150	350	300	450	400	<b>S801V50N3S</b>
610	185	315	375	250	150	200	200	500	450	600	500	<b>S801V65N3S</b>
680	200	375	445	—	200	250	200	600	500	700	600	<b>S801V72N3S</b>
810	250	450	500	—	—	300	300	700	600	900	700	<b>S801V85N3S</b>
890	290	510	560	—	—	400	350	700	600	900	700	<b>S801V10N3S<sup>⑤</sup></b>

For **Pump Option**, replace character **8** with **“P”** and also, see **Page V6-T35-58**.

**Notes**

- ① 690V is available only from T18 thru V85. Not available on U-Frames.
- ② For a longer ramp acceleration time of 0.5 to 360 seconds, see **Page V6-T35-58**.
- ③ For two-wire (level sensing) control, change the last digit from **S** to **B**.
- ④ U-Frame 500A does not have IEC certification.
- ⑤ For more information on optimum performance of the 1000A Frame Size V S801, see Appendix C of MN03902008E.

S801



### Standard Duty—15 Second Ramp, 4 Starts per Hour, 300% Current Limit at 50°C

Max. Current	Three-Phase Motors kW Rating (50 Hz)			hp Rating (60 Hz)		230V		460V		575–690V <sup>①</sup>		Catalog Number <sup>②③</sup>
	230V	380–400V	440V	200V 1.0SF	1.15SF	1.0SF	1.15SF	1.0SF	1.15SF	1.0SF	1.15SF	
<b>Frame Size N</b>												
34	9	15	18.5	10	7-1/2	10	10	25	20	30	25	<b>S801N37N3S</b>
63	15	30	33	20	15	20	20	40	40	60	50	<b>S801N66N3S</b>
<b>Frame Size R</b>												
96	25	45	55	30	25	30	30	75	60	75	75	<b>S801R10N3S</b>
120	33	63	63	40	30	40	40	75	75	100	100	<b>S801R13N3S</b>
<b>Frame Size T</b>												
150	45	80	90	50	40	50	50	100	100	150	125	<b>S801T18N3S</b>
215	63	110	132	60	60	75	60	150	150	200	150	<b>S801T24N3S</b>
278	80	147	160	75	75	100	75	200	200	250	250	<b>S801T30N3S</b>
<b>Frame Size U</b>												
320	90	160	185	100	75	125	100	250	200	300	250	<b>S801U36N3S</b>
460	110	200	220	125	100	150	125	300	250	350	300	<b>S801U42N3S</b>
460	140	250	280	150	125	150	150	350	300	450	400	<b>S801U50N3S<sup>④</sup></b>
<b>Frame Size V</b>												
320	90	160	185	100	75	125	100	250	200	300	250	<b>S801V36N3S</b>
380	110	200	220	125	100	150	125	300	250	350	300	<b>S801V42N3S</b>
460	140	250	280	150	125	150	150	350	300	450	400	<b>S801V50N3S</b>
610	185	315	375	250	150	200	200	500	450	600	500	<b>S801V65N3S</b>
680	200	375	445	—	200	250	200	600	500	700	600	<b>S801V72N3S</b>
830	257	450	500	—	—	300	300	700	600	900	700	<b>S801V85N3S</b>
960	302	510	540	—	—	350	300	800	700	900	800	<b>S801V10N3S<sup>⑤</sup></b>

For **Pump Option**, replace character **8** with **“P”** and also, see **Page V6-T35-58**.

**Notes**

- ① 690V is available only from T18 thru V85. Not available on U-Frames.
- ② For a longer ramp acceleration time of 0.5 to 360 seconds, see **Page V6-T35-58**.
- ③ For two-wire (level sensing) control, change the last digit from **S** to **B**.
- ④ U-Frame 500A does not have IEC certification.
- ⑤ For more information on optimum performance of the 1000A Frame Size V S801, see Appendix C of MN03902008E.

S801



#### Standard Duty—50 Second Ramp, 2 Starts per Hour, 300% Current Limit at 50°C

Max. Current	Three-Phase Motors kW Rating (50 Hz)			hp Rating (60 Hz)				575–690V <sup>①</sup>				Catalog Number <sup>②③</sup>
	230V	380–400V	440V	200V 1.0SF	1.15SF	230V 1.0SF	1.15SF	460V 1.0SF	1.15SF	1.0SF	1.15SF	
<b>Frame Size N</b>												
21	5.5	10	11	5	5	5	5	15	10	15	15	<b>S801N37N3S</b>
42	11	18.5	22	10	10	15	10	30	25	40	30	<b>S801N66N3S</b>
<b>Frame Size R</b>												
60	15	30	33	15	15	20	15	40	40	50	50	<b>S801R10N3S</b>
80	22	40	45	25	20	30	25	60	50	75	60	<b>S801R13N3S</b>
<b>Frame Size T</b>												
115	33	59	63	30	30	40	30	75	75	100	100	<b>S801T18N3S</b>
150	45	80	90	50	40	50	50	100	100	150	125	<b>S801T24N3S</b>
192	55	100	110	60	50	60	60	150	125	200	150	<b>S801T30N3S</b>
<b>Frame Size U</b>												
280	80	150	160	75	75	100	75	200	200	250	250	<b>S801U36N3S</b>
340	110	180	200	100	100	125	100	250	200	350	300	<b>S801U42N3S</b>
380	110	200	220	125	100	150	125	300	250	350	300	<b>S801U50N3S</b> <sup>④</sup>
<b>Frame Size V</b>												
280	80	150	160	75	75	100	75	200	200	250	250	<b>S801V36N3S</b>
340	110	180	200	100	100	125	100	250	200	350	300	<b>S801V42N3S</b>
380	110	200	220	125	100	150	125	300	250	350	300	<b>S801V50N3S</b>
420	129	220	257	150	125	150	150	350	300	450	350	<b>S801V65N3S</b>
480	147	257	295	150	150	200	150	400	350	500	450	<b>S801V72N3S</b>
590	180	315	375	200	150	200	200	500	400	600	500	<b>S801V85N3S</b>
650	205	370	415	250	200	250	200	500	450	600	500	<b>S801V10N3S</b> <sup>⑤</sup>

For **Pump Option**, replace character **8** with **“P”** and also, see **Page V6-T35-58**.

**Notes**

- ① 690V is available only from T18 thru V85. Not available on U-Frames.
- ② For a longer ramp acceleration time of 0.5 to 360 seconds, see **Page V6-T35-58**.
- ③ For two-wire (level sensing) control, change the last digit from **S** to **B**.
- ④ U-Frame 500A does not have IEC certification.
- ⑤ For more information on optimum performance of the 1000A Frame Size V S801, see Appendix C of MN03902008E.

S801



### Standard Duty—15 Second Ramp, 4 Starts per Hour, 450% Current Limit at 40°C

Max. Current	Three-Phase Motors kW Rating (50 Hz)			hp Rating (60 Hz)		230V		460V		575–690V <sup>①</sup>		Catalog Number <sup>②③</sup>
	230V	380–400V	440V	200V 1.0SF	1.15SF	1.0SF	1.15SF	1.0SF	1.15SF	1.0SF	1.15SF	
<b>Frame Size N</b>												
29	7.5	12.5	15	7-1/2	7-1/2	10	7-1/2	20	15	25	20	<b>S801N37N3S</b>
49	12.5	22	25	15	10	15	15	30	30	40	40	<b>S801N66N3S</b>
<b>Frame Size R</b>												
73	18.5	37	40	20	20	25	20	50	40	60	60	<b>S801R10N3S</b>
94	25	45	55	30	25	30	30	60	60	75	75	<b>S801R13N3S</b>
<b>Frame Size T</b>												
155	45	80	90	50	40	60	50	100	100	150	125	<b>S801T18N3S</b>
219	63	110	132	60	60	75	60	150	150	200	150	<b>S801T24N3S</b>
280	80	150	160	75	75	100	75	200	200	250	250	<b>S801T30N3S</b>
<b>Frame Size U</b>												
345	100	185	200	100	100	125	100	250	200	350	300	<b>S801U36N3S</b>
405	110	200	250	125	100	150	125	300	250	400	350	<b>S801U42N3S<sup>④</sup></b>
<b>Frame Size V</b>												
345	100	185	200	100	100	125	100	250	200	350	300	<b>S801V36N3S</b>
405	110	200	250	125	100	150	125	300	250	400	350	<b>S801V42N3S</b>
465	140	250	280	150	125	150	150	350	300	450	400	<b>S801V50N3S</b>
530	160	280	335	150	150	200	150	450	350	500	450	<b>S801V65N3S</b>
590	180	315	375	200	150	—	200	500	400	600	500	<b>S801V72N3S</b>
651	200	355	425	—	—	—	—	600	450	700	600	<b>S801V85N3S</b>
754	220	400	465	—	—	—	—	600	500	800	700	<b>S801V10N3S<sup>⑤</sup></b>

For **Pump Option**, replace character **8** with **"P"** and also, see **Page V6-T35-58**.

**Notes**

- ① 690V is available only from T18 thru V85. Not available on U-Frames.
- ② For a longer ramp acceleration time of 0.5 to 360 seconds, see **Page V6-T35-58**.
- ③ For two-wire (level sensing) control, change the last digit from **S** to **B**.
- ④ U-Frame 500A does not have IEC certification.
- ⑤ For more information on optimum performance of the 1000A Frame Size V S801, see Appendix C of MN03902008E.

S801



#### Standard Duty—30 Second Ramp, 4 Starts per Hour, 450% Current Limit at 40°C

Max. Current	Three-Phase Motors kW Rating (50 Hz)			hp Rating (60 Hz)				575–690V <sup>①</sup>				Catalog Number <sup>②③</sup>
	230V	380–400V	440V	200V 1.0SF	1.15SF	230V 1.0SF	1.15SF	460V 1.0SF	1.15SF	1.0SF	1.15SF	
<b>Frame Size N</b>												
21	5.5	10	12.5	5	5	5	5	15	10	15	15	<b>S801N37N3S</b>
40	11	18.5	22	10	10	10	10	30	25	30	30	<b>S801N66N3S</b>
<b>Frame Size R</b>												
55	15	25	30	15	15	20	15	40	30	50	40	<b>S801R10N3S</b>
75	22	37	45	20	20	25	20	50	50	60	60	<b>S801R13N3S</b>
<b>Frame Size T</b>												
151	45	80	90	50	40	50	50	100	100	150	125	<b>S801T18N3S</b>
215	63	110	132	60	60	75	60	150	150	200	150	<b>S801T24N3S</b>
264	80	140	160	75	75	100	75	200	150	250	200	<b>S801T30N3S</b>
<b>Frame Size U</b>												
300	90	160	185	100	75	100	100	200	200	300	250	<b>S801U36N3S</b>
340	100	180	200	100	100	125	100	250	200	350	300	<b>S801U42N3S<sup>④</sup></b>
380	110	200	220	125	100	150	125	300	250	350	300	<b>S801U50N3S</b>
<b>Frame Size V</b>												
300	90	160	185	100	75	100	100	200	200	300	250	<b>S801V36N3S</b>
340	100	180	200	100	100	125	100	250	200	350	300	<b>S801V42N3S</b>
380	110	200	220	125	100	150	125	300	250	350	300	<b>S801V50N3S</b>
420	129	220	257	150	125	150	150	350	300	450	350	<b>S801V65N3S</b>
460	140	250	280	150	125	150	150	350	300	450	400	<b>S801V72N3S</b>
500	150	257	300	150	150	200	150	400	350	500	450	<b>S801V85N3S</b>
560	160	277	325	200	150	250	200	500	400	600	500	<b>S801V10N3S<sup>⑤</sup></b>

For **Pump Option**, replace character **8** with **“P”** and also, see **Page V6-T35-58**.

**Notes**

- ① 690V is available only from T18 thru V85. Not available on U-Frames.
- ② For a longer ramp acceleration time of 0.5 to 360 seconds, see **Page V6-T35-58**.
- ③ For two-wire (level sensing) control, change the last digit from **S** to **B**.
- ④ U-Frame 500A does not have IEC certification.
- ⑤ For more information on optimum performance of the 1000A Frame Size V S801, see Appendix C of MN03902008E.



### Severe Duty Ratings

The table below is the base ratings for the **IT** Soft Starter. The tables included in this catalog are meant to be a selection table for different applications, but to match a unit to your exact application, consult with your local Eaton representative or call our Technical Resource Center.

### Severe Duty Ratings

Starting Method	Ramp Current % of FLA	Ramp Time Seconds	Starts per Hour	Ambient Temperature
Soft start	450%	30 sec.	4	50°C
Full voltage	500%	10 sec.	10	50°C
Wye-delta	350%	65 sec.	3	50°C
80% RVAT	480%	25 sec.	4	50°C
65% RVAT	390%	40 sec.	4	50°C
50% RVAT	300%	60 sec.	4	50°C

Severe duty ratings are defined as any combination of parameters that exceed the standard duty ratings

where the ramp time is over 30 seconds, the number of starts per hour exceeds 4, or the current limit set is over

300%. *Example:* 35-second ramp, 5 starts per hour, 350% current limit at 40°C ambient.

### S801



### Severe Duty—>30 Second Ramp, >4 Starts per Hour or >300% Current Limit

Max. Current	Three-Phase Motor kW Rating (50 Hz)			hp Rating (60 Hz)								Catalog Number <sup>①②</sup>
	230V	380–400V	440V	200V		230V		460V		575V		
				1.0SF	1.15SF	1.0SF	1.15SF	1.0SF	1.15SF	1.0SF	1.15SF	
<b>Frame Size N</b>												
22	5.5	10	11	5	5	7-1/2	5	15	10	20	15	<b>S801N37N3S</b>
42	11	18.5	22	10	10	15	10	30	25	40	30	<b>S801N66N3S</b>
<b>Frame Size R</b>												
65	15	30	33	15	15	20	15	50	40	50	50	<b>S801R10N3S</b>
80	22	40	45	25	20	30	25	60	50	75	60	<b>S801R13N3S</b>
<b>Frame Size T</b>												
115	33	59	63	30	30	40	30	75	75	100	100	<b>S801T18N3S</b>
150	45	80	90	50	40	50	50	100	100	150	125	<b>S801T24N3S</b>
192	55	100	110	60	50	75	60	150	125	200	150	<b>S801T30N3S</b>
<b>Frame Size U</b>												
240	75	110	147	75	60	75	75	200	150	200	200	<b>S801U36N3S</b>
305	90	160	185	100	75	100	100	250	200	300	250	<b>S801U42N3S</b>
365	110	185	220	125	100	150	125	300	250	350	300	<b>S801U50N3S</b> <sup>③</sup>
<b>Frame Size V</b>												
240	75	110	147	75	60	75	75	200	150	200	200	<b>S801V36N3S</b>
305	90	160	185	100	75	100	100	250	200	300	250	<b>S801V42N3S</b>
365	110	185	220	125	100	150	125	300	250	350	300	<b>S801V50N3S</b>
420	129	220	257	150	125	150	150	350	300	450	350	<b>S801V65N3S</b>
480	147	257	295	150	150	200	150	400	350	500	450	<b>S801V72N3S</b>
525	160	280	335	150	150	200	150	450	350	500	450	<b>S801V85N3S</b>
600	185	315	375	200	150	250	200	500	450	600	500	<b>S801V10N3S</b> <sup>④</sup>

#### Notes

- ① For a longer ramp acceleration time of 0.5 to 360 seconds, see **Page V6-T35-58**.
- ② For two-wire (level sensing) control, change the last digit from **S** to **B**.
- ③ U-Frame 500A unit does not have IEC certification.
- ④ For more information on optimum performance of the 1000A Frame Size V S801, see Appendix C of MN03902008E.

#### Inside-the-Delta Standard Duty Ratings

S801



#### Inside-the-Delta Standard Duty—15 Second Ramp, 4 Starts per Hour, 300% Current Limit at 40°C Ambient

Max. Continuous Motor Line Current	Three-Phase Motor kW Rating (50 Hz)			hp Rating (60 Hz)								Catalog Number
	230V	380–400V	440V	200V		230V		460V		575V		
				1.0SF	1.15SF	1.0SF	1.15SF	1.0SF	1.15SF	1.0SF	1.15SF	
<b>Frame Size N</b>												
65	10	18.5	18.5	15	15	15	15	40	30	50	50	<b>S801N37N3D</b>
114	18.5	30	37	30	25	30	30	75	60	100	75	<b>S801N66N3D</b>
<b>Frame Size R</b>												
182	30	55	59	50	40	60	50	125	100	150	125	<b>S801R10N3D</b>
234	40	63	80	60	50	75	60	150	125	200	150	<b>S801R13N3D</b>
<b>Frame Size T</b>												
311	51	90	110	100	75	100	100	250	200	250	250	<b>S801T18N3D</b>
415	75	110	147	125	100	125	125	300	250	300	300	<b>S801T24N3D</b>
526	90	160	185	150	125	150	150	400	300	400	400	<b>S801T30N3D</b>
<b>Frame Size U</b>												
623	110	185	220	200	150	250	200	450	400	550	450	<b>S801U36N3D</b>
727	129	220	257	250	200	300	250	550	450	700	550	<b>S801U42N3D</b>
865	150	257	300	250	250	300	250	600	550	750	700	<b>S801U50N3D</b> <sup>①②</sup>
<b>Frame Size V</b>												
623	110	185	220	200	150	250	200	450	400	550	450	<b>S801V36N3D</b>
727	129	220	257	250	200	300	250	550	450	700	550	<b>S801V42N3D</b>
865	150	257	300	250	250	300	250	600	550	750	700	<b>S801V50N3D</b>
1125	200	355	425	400	300	400	300	750	700	900	750	<b>S801V65N3D</b>
1246	—	—	—	—	—	—	—	—	—	—	—	<b>S801V72N3D</b>
1471	—	—	—	—	—	—	—	—	—	—	—	<b>S801V85N3D</b>
—	—	—	—	—	—	—	—	—	—	—	—	<b>S801V10N3D</b> <sup>③</sup>

**Notes**

- ① 15 sec. start, 300% inrush, 40°C, 1 start every 15 minutes. If these start parameters are exceeded, please refer to 290 mm V-Frame, 865A Inside-the-Delta Starter.
- ② U-Frame 500A unit does not have IEC certification.
- ③ For more information on optimum performance of the 1000A Frame Size V Inside-the-Delta S801, see Appendix C of MN03902009E.

S801



**Inside-the-Delta Standard Duty—25 Second Ramp, 4 Starts per Hour, 300% Current Limit at 40°C Ambient**

Max. Continuous Motor Line Current	Three-Phase Motor kW Rating (50 Hz)			hp Rating (60 Hz)								Catalog Number
	230V	380–400V	440V	200V 1.0SF	1.15SF	230V 1.0SF	1.15SF	460V 1.0SF	1.15SF	575V 1.0SF	1.15SF	
<b>Frame Size N</b>												
58	9	15	18.5	15	10	15	15	40	30	50	40	<b>S801N37N3D</b>
108	15	30	33	30	25	30	30	60	60	100	75	<b>S801N66N3D</b>
<b>Frame Size R</b>												
164	25	45	55	50	40	50	50	125	100	125	125	<b>S801R10N3D</b>
206	33	63	63	60	50	60	50	125	125	150	150	<b>S801R13N3D</b>
<b>Frame Size T</b>												
257	45	80	90	75	60	75	60	150	150	250	200	<b>S801T18N3D</b>
365	63	110	132	100	100	125	100	250	250	300	250	<b>S801T24N3D</b>
477	80	147	160	125	125	150	125	300	300	400	400	<b>S801T30N3D</b>
<b>Frame Size U</b>												
554	90	160	185	150	125	200	150	400	300	450	400	<b>S801U36N3D</b>
646	110	200	220	200	150	250	200	500	400	550	450	<b>S801U42N3D</b>
796	140	250	280	250	200	250	250	550	500	700	600	<b>S801U50N3D</b> ①②
<b>Frame Size V</b>												
554	90	160	185	150	125	200	150	400	300	450	400	<b>S801V36N3D</b>
646	110	200	220	200	150	250	200	500	400	550	450	<b>S801V42N3D</b>
796	140	250	280	250	200	250	250	550	500	700	600	<b>S801V50N3D</b>
1055	185	315	375	400	250	300	300	800	700	900	750	<b>S801V65N3D</b>
1176	200	375	445	—	300	400	300	900	800	900	900	<b>S801V72N3D</b>
1358	—	—	—	—	—	—	—	—	—	—	—	<b>S801V85N3D</b>
—	—	—	—	—	—	—	—	—	—	—	—	<b>S801V10N3D</b> ③

**Notes**

- ① 15 sec. start, 300% inrush, 40°C, 1 start every 15 minutes. If these start parameters are exceeded, please refer to 290 mm V-Frame, 796A Inside-the-Delta Starter.
- ② U-Frame 500A unit does not have IEC certification.
- ③ For more information on optimum performance of the 1000A Frame Size V Inside-the-Delta S801, see Appendix C of MN03902009E.

S801



**Inside-the-Delta Standard Duty—15 Second Ramp, 4 Starts per Hour, 300% Current Limit at 50°C Ambient**

Max. Continuous Motor Line Current	Three-Phase Motor kW Rating (50 Hz)			hp Rating (60 Hz)								Catalog Number
	230V	380–400V	440V	200V		230V		460V		575V		
				1.0SF	1.15SF	1.0SF	1.15SF	1.0SF	1.15SF	1.0SF	1.15SF	
<b>Frame Size N</b>												
58	9	15	18.5	15	10	15	15	40	30	50	40	<b>S801N37N3D</b>
108	15	30	33	30	25	30	30	60	60	100	75	<b>S801N66N3D</b>
<b>Frame Size R</b>												
164	25	45	55	50	40	50	50	125	100	125	125	<b>S801R10N3D</b>
206	33	63	63	60	50	60	60	125	125	150	150	<b>S801R13N3D</b>
<b>Frame Size T</b>												
257	45	80	90	75	60	75	75	150	150	250	200	<b>S801T18N3D</b>
365	63	110	132	100	100	125	100	250	250	300	250	<b>S801T24N3D</b>
477	80	147	160	125	125	150	125	300	300	400	400	<b>S801T30N3D</b>
<b>Frame Size U</b>												
554	90	160	185	150	125	200	150	400	300	450	400	<b>S801U36N3D</b>
646	110	200	220	200	150	250	200	450	400	550	450	<b>S801U42N3D</b>
796	140	250	280	250	200	250	250	550	450	700	600	<b>S801U50N3D</b> ①
<b>Frame Size V</b>												
554	90	160	185	150	125	200	150	400	300	450	400	<b>S801V36N3D</b>
646	110	200	220	200	150	250	200	450	400	550	450	<b>S801V42N3D</b>
796	140	250	280	250	200	250	250	550	450	700	600	<b>S801V50N3D</b>
1055	185	315	375	400	250	300	300	750	700	900	750	<b>S801V65N3D</b>
1176	200	375	445	—	—	—	—	—	—	—	—	<b>S801V72N3D</b>
1358	257	450	500	—	—	—	—	—	—	—	—	<b>S801V85N3D</b>
—	—	—	—	—	—	—	—	—	—	—	—	<b>S801V10N3D</b> ②

**Notes**

- ① U-Frame 500A unit does not have IEC certification.
- ② For more information on optimum performance of the 1000A Frame Size V Inside-the-Delta S801, see Appendix C of MN03902009E.

S801



**Inside-the-Delta Standard Duty—50 Second Ramp, 2 Starts per Hour, 300% Current Limit at 50°C Ambient**

Max. Continuous Motor Line Current	Three-Phase Motor												Catalog Number
	kW Rating (50 Hz)			hp Rating (60 Hz)									
	230V	380-400V	440V	200V		230V		460V		575V			
			1.0SF	1.15SF	1.0SF	1.15SF	1.0SF	1.15SF	1.0SF	1.15SF			
<b>Frame Size N</b>													
36	5.5	10	11	7-1/2	7-1/2	7-1/2	7-1/2	25	15	25	25		S801N37N3D
73	11	18.5	22	15	15	25	15	50	40	60	50		S801N66N3D
<b>Frame Size R</b>													
103	15	30	33	25	25	30	25	60	60	75	75		S801R10N3D
138	22	40	45	40	30	50	40	100	75	125	100		S801R13N3D
<b>Frame Size T</b>													
199	33	59	63	50	50	60	50	125	125	150	150		S801T18N3D
257	45	80	90	75	60	75	75	150	150	250	200		S801T24N3D
324	55	100	110	100	75	100	100	250	200	300	250		S801T30N3D
<b>Frame Size U</b>													
485	80	150	160	125	125	150	125	300	300	400	400		S801U36N3D
580	100	180	200	150	150	200	150	400	300	550	450		S801U42N3D
646	110	200	220	200	150	250	200	450	400	550	450		S801U50N3D <sup>①</sup>
<b>Frame Size V</b>													
485	80	150	160	125	125	150	125	300	300	400	400		S801V36N3D
580	100	180	200	150	150	200	150	400	300	550	450		S801V42N3D
646	110	200	220	200	150	250	200	450	400	550	450		S801V50N3D
727	129	220	257	250	200	250	250	550	500	700	550		S801V65N3D
816	147	257	295	250	250	300	250	600	550	750	700		S801V72N3D
1021	180	315	375	300	250	300	300	750	600	900	750		S801V85N3D
—	—	—	—	—	—	—	—	—	—	—	—		S801V10N3D <sup>②</sup>

**Notes**

- ① U-Frame 500A unit does not have IEC certification.
- ② For more information on optimum performance of the 1000A Frame Size V Inside-the-Delta S801, see Appendix C of MN03902009E.

S801



**Inside-the-Delta Standard Duty—15 Second Ramp, 4 Starts per Hour, 450% Current Limit at 40°C Ambient**

Max. Continuous Motor Line Current	Three-Phase Motor kW Rating (50 Hz)			hp Rating (60 Hz)								Catalog Number
	230V	380–400V	440V	200V 1.0SF	1.15SF	230V 1.0SF	1.15SF	460V 1.0SF	1.15SF	575V 1.0SF	1.15SF	
<b>Frame Size N</b>												
47	7.5	12.5	15	10	10	15	10	30	25	40	30	<b>S801N37N3D</b>
83	12.5	22	25	25	15	25	25	50	50	60	60	<b>S801N66N3D</b>
<b>Frame Size R</b>												
126	18.5	37	40	30	30	40	30	75	60	100	100	<b>S801R10N3D</b>
162	25	45	55	50	40	50	50	100	100	125	125	<b>S801R13N3D</b>
<b>Frame Size T</b>												
266	45	80	90	75	60	100	75	150	150	250	200	<b>S801T18N3D</b>
379	63	110	132	100	100	125	100	250	250	300	250	<b>S801T24N3D</b>
485	80	150	160	125	125	150	125	300	300	400	400	<b>S801T30N3D</b>
<b>Frame Size U</b>												
580	100	185	200	150	150	200	150	400	300	550	450	<b>S801U36N3D</b>
695	110	200	250	200	150	250	200	450	400	600	550	<b>S801U42N3D</b>
798	140	250	280	250	200	250	250	550	450	700	600	<b>S801U50N3D</b> <sup>①</sup>
<b>Frame Size V</b>												
580	100	185	200	150	150	200	150	400	300	550	450	<b>S801V36N3D</b>
695	110	200	250	200	150	250	200	450	400	600	550	<b>S801V42N3D</b>
798	140	250	280	250	200	250	250	550	450	700	600	<b>S801V50N3D</b>
908	160	280	335	250	250	300	250	700	550	750	700	<b>S801V65N3D</b>
1021	—	—	—	—	—	—	—	—	—	—	—	<b>S801V72N3D</b>
1125	—	—	—	—	—	—	—	—	—	—	—	<b>S801V85N3D</b>

**Note**

<sup>①</sup> U-Frame 500A unit does not have IEC certification.

S801



**Inside-the-Delta Standard Duty—30 Second Ramp, 4 Starts per Hour,  
450% Current Limit at 40°C Ambient**

Max. Continuous Motor Line Current	Three-Phase Motor kW Rating (50 Hz)			hp Rating (60 Hz)								Catalog Number
	230V	380–400V	440V	200V 1.0SF	1.15SF	230V 1.0SF	1.15SF	460V 1.0SF	1.15SF	575V 1.0SF	1.15SF	
<b>Frame Size N</b>												
36	5.5	10	12.5	7-1/2	7-1/2	7-1/2	7-1/2	25	15	25	25	<b>S801N37N3D</b>
69	11	18.5	22	15	15	15	15	50	40	50	50	<b>S801N66N3D</b>
<b>Frame Size R</b>												
96	15	25	30	25	25	30	25	60	50	75	60	<b>S801R10N3D</b>
130	22	37	45	30	30	40	30	75	75	100	100	<b>S801R13N3D</b>
<b>Frame Size T</b>												
257	45	80	90	75	60	75	75	150	150	250	200	<b>S801T18N3D</b>
365	63	110	132	100	100	125	100	250	250	300	250	<b>S801T24N3D</b>
448	80	140	160	125	125	150	125	300	250	400	300	<b>S801T30N3D</b>
<b>Frame Size U</b>												
503	90	160	185	150	125	150	150	300	300	450	400	<b>S801U36N3D</b>
580	100	180	200	150	150	200	150	400	300	550	450	<b>S801U42N3D</b>
646	110	200	220	200	150	250	200	450	400	550	450	<b>S801U50N3D</b> ①
<b>Frame Size V</b>												
503	90	160	185	150	125	150	150	300	300	450	400	<b>S801V36N3D</b>
580	100	180	200	150	150	200	150	400	300	550	450	<b>S801V42N3D</b>
646	110	200	220	200	150	250	200	450	400	550	450	<b>S801V50N3D</b>
727	129	220	257	250	200	250	250	550	450	700	550	<b>S801V65N3D</b>
796	—	—	—	—	—	—	—	—	—	—	—	<b>S801V72N3D</b>
865	—	—	—	—	—	—	—	—	—	—	—	<b>S801V85N3D</b>

**Note**

① U-Frame 500A unit does not have IEC certification.

#### Inside-the-Delta Severe Duty Ratings

Severe duty ratings are defined as any combination of parameters that exceed the standard duty ratings where the ramp time is over 30 seconds, the number of starts per hour exceeds 4, or the current limit set is over 300%.

Example: 35-second ramp, 5 starts per hour 350% current limit at 40°C ambient.

S801



#### Inside-the-Delta Severe Duty

Max. Continuous Motor Line Current	Three-Phase Motor kW Rating (50 Hz)			hp Rating (60 Hz)								Catalog Number
	230V	380–400V	440V	200V		230V		460V		575V		
				1.0SF	1.15SF	1.0SF	1.15SF	1.0SF	1.15SF	1.0SF	1.15SF	
<b>Frame Size N</b>												
39	5.5	10	11	7-1/2	7-1/2	10	7-1/2	25	15	30	25	<b>S801N37N3D</b>
73	11	18.5	22	15	15	25	15	50	40	60	50	<b>S801N66N3D</b>
<b>Frame Size R</b>												
111	15	30	33	25	25	30	25	75	60	75	75	<b>S801R10N3D</b>
138	22	40	45	40	30	50	40	100	75	120	100	<b>S801R13N3D</b>
<b>Frame Size T</b>												
199	33	59	63	50	50	60	50	125	125	150	150	<b>S801T18N3D</b>
257	45	80	90	75	60	75	75	150	150	250	200	<b>S801T24N3D</b>
324	55	100	110	100	75	100	100	250	200	300	250	<b>S801T30N3D</b>
<b>Frame Size U</b>												
415	75	110	147	125	100	125	125	300	250	300	300	<b>S801U36N3D</b>
526	90	160	185	150	120	150	150	400	300	450	400	<b>S801U42N3D</b>
623	110	185	220	200	150	250	200	450	400	550	450	<b>S801U50N3D</b> ①
<b>Frame Size V</b>												
415	75	110	147	125	100	125	125	300	250	300	300	<b>S801V36N3D</b>
526	90	160	185	150	120	150	150	400	300	450	400	<b>S801V42N3D</b>
623	110	185	220	200	150	250	200	450	400	550	450	<b>S801V50N3D</b>
727	129	220	257	250	200	250	250	550	450	700	550	<b>S801V65N3D</b>
816	147	257	295	250	250	300	250	600	550	750	700	<b>S801V72N3D</b>
908	160	280	335	250	250	300	250	700	550	750	700	<b>S801V85N3D</b>
—	—	—	—	—	—	—	—	—	—	—	—	<b>S801V10N3D</b> ②

**Notes**

- ① U-Frame 500A unit does not have IEC certification.
- ② For more information on optimum performance of the 1000A Frame Size V Inside-the-Delta S801, see Appendix C of MN03902009E.



### Accessories

#### Lug Kits

The T and U frame (200 mm) and V frame (290 mm) each have different lug options based on your wiring needs.

Each lug kit contains three lugs that can be mounted on either the load or line side.

#### Lug Kit



#### Lug Kits

Frame Size	Frame Designation	Description	Catalog Number
200 mm SSRV	T, U	2 cable connections, 4 AWG to 1/0 cable	<b>EML22</b>
		1 cable connection, 4/0 to 500 kcmil cable	<b>EML23</b>
		2 cable connections, 4/0 to 500 kcmil cable	<b>EML24</b>
		1 cable connection, 2/0 to 300 kcmil cable	<b>EML25</b>
		2 cable connections, 2/0 to 300 kcmil cable	<b>EML26</b>
		290 mm SSRV	V
		4 cable connections, 4/0 to 500 kcmil cable	<b>EML30</b>
		6 cable connections, 4/0 to 500 kcmil cable	<b>EML32</b>
		4 cable connections, 2/0 to 300 kcmil cable	<b>EML33</b> <sup>①</sup>

#### Power Supplies

24 Vdc power supply that can be used with the S801 SSRV or as a stand-alone device.

#### Power Supplies

Description	Catalog Number
85–264 Vac input 24 Vdc output	<b>PSG240E</b>
360–575 Vac input 24 Vdc output	<b>PSG240F</b>

#### Lug Cover Kits

Replacement covers for the T- and V-Frame are available in case of damage to the existing covers.

#### Lug Cover Kits

Description	Catalog Number
Lug cover T-, U-Frame	<b>EML27</b>
Lug cover V-Frame	<b>EML34</b>

#### IP20 Kits

#### IP20 Kits

Description	Catalog Number
N-Frame kit	<b>SS-IP20-N</b>
R-Frame kit	<b>SS-IP20-R</b>
T- and U-Frame kit	<b>SS-IP20-TU</b>
V-Frame kit	<b>SS-IP20-V</b>

#### Surge Suppressors

The surge suppressor can mount on either the line or load side of the **IT** Soft Starter. It is designed to clip the line voltage (or load side induced voltage).

#### Surge Suppressor



#### Surge Suppressors

Description	Catalog Number
600V MOV for 200 mm and 290 mm units	<b>EMS39</b>
690V MOV for 200 mm and 290 mm units <sup>②</sup>	<b>EMS41</b>

#### Notes

- ① The EML33 does not have a CSA listing.
- ② T-Frame only.

#### Mounting Plates

The mounting plates are designed to help make it easy to install or retrofit the soft starter into enclosures and MCCs. The soft starter can be mounted onto the plate prior to installation. The mounting plate is designed with tear drop mounting holes for easier installation.

#### Mounting Plates

Description	Catalog Number
Mounting plate N-Frame	EMM13N
Mounting plate R-Frame	EMM13R
Mounting plate T-, U-Frame	EMM13T
Mounting plate V-Frame	EMM13V

#### Vibration Plates

The vibration plates allow the soft starter to be applied in high shock and vibration applications. The vibration plate allows vibration up to 5g and shock in up to 40g. The soft starter is mounted onto the vibration plate prior to installation in the panel.

#### Vibration Plates

Description	Catalog Number
Vibration plate N-Frame	EMM14N
Vibration plate R-Frame	EMM14R
Vibration plate T-, U-Frame	EMM14T
Vibration plate V-Frame	EMM14V

#### Adapter Plates

The adapter plate allows customers to retrofit a V-Frame 290 mm soft starter with the U-Frame 200 mm soft starter.

#### Adapter Plates

Description	Catalog Number
Adapter plates <sup>②</sup>	EMM13U

#### Control Wire Connector

#### Control Wire Connector

Description	Catalog Number
12-pin, 5 mm pitch connector for control wiring	EMA75

#### Control Interface Module

The Control Interface Module (CIM) is available as a replacement part in two versions.

#### CIM

Description	Catalog Number
Blank cover (filler)	EMA68
CIM for standard unit	EMA71
CIM for pump control option	EMA72
Panel mounting kit	
3 ft cable	EMA69A
5 ft cable	EMA69B
8 ft cable	EMA69C
10 ft cable	EMA69D

#### Options

##### Pump Control

For pump control option, use the following table to select the product you are looking for. For sizing information, use the tables on **Pages V6-T35-43 to V6-T35-56**.

##### Pump Control Option

Frame Size	Max. Current	Catalog Number
N	37	S801N37P3S
	66	S801N66P3S
R	105	S801R10P3S
	135	S801R13P3S
T	180	S801T18P3S
	240	S801T24P3S
	304	S801T30P3S
U	360	S801U36P3S
	420	S801U42P3S
	500	S801U50P3S <sup>①</sup>
V	360	S801V36P3S
	420	S801V42P3S
	500	S801V50P3S
	650	S801V65P3S
	720	S801V72P3S
	850	S801V85P3S
	1000	S801V10P3S

##### Extended Ramp

For a longer ramp acceleration time of 0.5–360 seconds, change the last digit in the catalog number from **Page V6-T35-43** to **L**.

##### Extended Ramp Option

Frame Size	Max. Current	Catalog Number
N	37	S801N37N3L
	66	S801N66N3L
R	105	S801R10N3L
	135	S801R13N3L
T	180	S801T18N3L
	240	S801T24N3L
	304	S801T30N3L
U	360	S801U36N3L
	420	S801U42N3L
	500	S801U50N3L <sup>①</sup>
V	360	S801V36N3L
	420	S801V42N3L
	500	S801V50N3L
	650	S801V65N3L
	720	S801V72N3L
	850	S801V85N3L
	1000	S801V10N3L

##### Extended Ramp and 690V Option

For voltage ratings of 690V, use the table below.

##### 690V Option

Frame Size	Max. Current	Catalog Number
T	180	S801T18V3L
	240	S801T24V3L
	304	S801T30V3L
V	360	S801V36V3L
	420	S801V42V3L
	500	S801V50V3L
	650	S801V65V3L
	720	S801V72V3L
	850	S801V85V3L

##### Cooling Fan Kit

The EMM18 cooling fan kit mounts on either side of any frame size S801 Soft Starter to provide additional printed circuit board cooling in high ambient operating temperatures.

##### Cooling Fan Kit

Description	Catalog Number
Fan Kit	EMM18

#### Notes

- <sup>①</sup> U-Frame 500A unit does not have IEC certification.
- <sup>②</sup> For more information, see Pub 51719.

## Technical Data and Specifications

### IT. Soft Starters—S801

Description	S801 Soft Starter (Partial Catalog Number)			
	S801N37	S801N66	S801R10	S801R13
Max. current capacity	37	66	105	135
<b>General Information</b>				
Bypass mechanical lifespan	10M	10M	10M	10M
Insulating voltage Ui	660V	660V	660V	660V
Ramp time range	0.5–180 seconds (0.5–360 seconds extended ramp)	0.5–180 seconds (0.5–360 seconds extended ramp)	0.5–180 seconds (0.5–360 seconds extended ramp)	0.5–180 seconds (0.5–360 seconds extended ramp)
Resistance to vibration	3g	3g	3g	3g
Resistance to shock	15g	15g	15g	15g
<b>Electrical Information</b>				
Operating voltage	200–600V	200–600V	200–600V	200–600V
Operating frequency	47–63 Hz	47–63 Hz	47–63 Hz	47–63 Hz
Overload setting	30–100%	30–100%	30–100%	30–100%
Trip class	5, 10, 20 and 30	5, 10, 20 and 30	5, 10, 20 and 30	5, 10, 20 and 30
<b>Cabling Capacity (IEC 947)</b>				
Number of conductors	1	1	1	1
Wire sizes	14–2	14–2	14–4/0	14–4/0
Type of connectors	Box lug	Box lug	Box lug	Box lug
<b>Control Wiring (12-Pin)</b>				
Wire sizes in AWG	22–14	22–14	22–14	22–14
Number of conductors (stranded)	2 (or one AWG 12)	2 (or one AWG 12)	2 (or one AWG 12)	2 (or one AWG 12)
Torque requirements in lb-in	3.5	3.5	3.5	3.5
Solid, stranded or flexible max. size in mm <sup>2</sup>	3.31	3.31	3.31	3.31
<b>Control Power Requirements</b>				
Voltage range (24V ±10%)	21.6–26.4	21.6–26.4	21.6–26.4	21.6–26.4
Steady-state current amps	1.0	1.0	1.0	1.0
Inrush current amps	10	10	10	10
Ripple	1%	1%	1%	1%
<b>Relays (1) Class A and C</b>				
Voltage AC—maximum	240	240	240	240
Voltage DC—maximum	120	120	120	120
Amps—maximum	3	3	3	3
<b>Environment</b>				
Temperature—operating	–30 to 50°C (no derating) consult factory for operation >50°C	–30 to 50°C (no derating) consult factory for operation >50°C	–30 to 50°C (no derating) consult factory for operation >50°C	–30 to 50°C (no derating) consult factory for operation >50°C
Temperature—storage	–50 to 70°C	–50 to 70°C	–50 to 70°C	–50 to 70°C
Altitude	<2000m—consult factory for operation >2000m	<2000m—consult factory for operation >2000m	<2000m—consult factory for operation >2000m	<2000m—consult factory for operation >2000m
Humidity	<95% noncondensing	<95% noncondensing	<95% noncondensing	<95% noncondensing
Operating position	Any	Any	Any	Any
Pollution degree IEC947-1	3	3	3	3
Impulse withstand voltage IEC947-4-1	6000V	6000V	6000V	6000V

## 17. Soft Starters—S801, continued

Description	S801 Soft Starter (Partial Catalog Number)			
	S801T18	S801T24	S801T30	S801U36
Max. current capacity	180	240	304	360
<b>General Information</b>				
Bypass mechanical lifespan	10M	10M	10M	10M
Insulating voltage $U_i$	660V	660V	660V	660V
Ramp time range	0.5–180 seconds (0.5–360 seconds extended ramp)	0.5–180 seconds (0.5–360 seconds extended ramp)	0.5–180 seconds (0.5–360 seconds extended ramp)	0.5–180 seconds (0.5–360 seconds extended ramp)
Resistance to vibration	3g	3g	3g	3g
Resistance to shock	15g	15g	15g	15g
<b>Electrical Information</b>				
Operating voltage	200–600V	200–600V	200–600V	200–600V
Operating frequency	47–63 Hz	47–63 Hz	47–63 Hz	47–63 Hz
Overload setting	30–100%	30–100%	30–100%	30–100%
Trip class	5, 10, 20 and 30	5, 10, 20 and 30	5, 10, 20 and 30	5, 10, 20 and 30
<b>Cabling Capacity (IEC 947)</b>				
Number of conductors	1 or 2	1 or 2	1 or 2	1 or 2
Wire sizes	4 AWG to 500 kcmil	4 AWG to 500 kcmil	4 AWG to 500 kcmil	4 AWG to 500 kcmil
Type of connectors	Add-on lug kit	Add-on lug kit	Add-on lug kit	Add-on lug kit
<b>Control Wiring (12-Pin)</b>				
Wire sizes in AWG	22–14	22–14	22–14	22–14
Number of conductors (stranded)	2 (or one AWG 12)	2 (or one AWG 12)	2 (or one AWG 12)	2 (or one AWG 12)
Torque requirements in lb-in	3.5	3.5	3.5	3.5
Solid, stranded or flexible max. size in mm <sup>2</sup>	3.31	3.31	3.31	3.31
<b>Control Power Requirements</b>				
Voltage range (24V ±10%)	21.6–26.4	21.6–26.4	21.6–26.4	21.6–26.4
Steady-state current amps	1.0	1.0	1.0	1.0
Inrush current amps	10	10	10	10
Ripple	1%	1%	1%	1%
<b>Relays (1) Class A and C</b>				
Voltage AC—maximum	240	240	240	240
Voltage DC—maximum	120	120	120	120
Amps—maximum	3	3	3	3
<b>Environment</b>				
Temperature—operating	–30 to 50°C (no derating) consult factory for operation >50°C	–30 to 50°C (no derating) consult factory for operation >50°C	–30 to 50°C (no derating) consult factory for operation >50°C	–30 to 50°C (no derating) consult factory for operation >50°C
Temperature—storage	–50 to 70°C	–50 to 70°C	–50 to 70°C	–50 to 70°C
Altitude	<2000m—consult factory for operation >2000m	<2000m—consult factory for operation >2000m	<2000m—consult factory for operation >2000m	<2000m—consult factory for operation >2000m
Humidity	<95% noncondensing	<95% noncondensing	<95% noncondensing	<95% noncondensing
Operating position	Any	Any	Any	Any
Pollution degree IEC947-1	3	3	3	3
Impulse withstand voltage IEC947-4-1	6000V	6000V	6000V	6000V

**Notes**

- ① U-Frame 500A unit does not have IEC certification.
- ② UL recognized component.

**IT. Soft Starters—S801, continued**

Description	S801 Soft Starter (Partial Catalog Number)			
	S801U42	S801U50 <sup>①</sup>	S801V36	S801V42
Max. current capacity	420	500	360	420
<b>General Information</b>				
Bypass mechanical lifespan	10M	10M	10M	10M
Insulating voltage U <sub>i</sub>	660V	660V	660V	660V
Ramp time range	0.5–180 seconds (0.5–360 seconds extended ramp)	0.5–180 seconds (0.5–360 seconds extended ramp)	0.5–180 seconds (0.5–360 seconds extended ramp)	0.5–180 seconds (0.5–360 seconds extended ramp)
Resistance to vibration	3g	3g	3g	3g
Resistance to shock	15g	15g	15g	15g
<b>Electrical Information</b>				
Operating voltage	200–600V	200–600V	200–600V	200–600V
Operating frequency	47–63 Hz	47–63 Hz	47–63 Hz	47–63 Hz
Overload setting	30–100%	30–100%	30–100%	30–100%
Trip class	5, 10, 20 and 30	5, 10, 20 and 30	5, 10, 20 and 30	5, 10, 20 and 30
<b>Cabling Capacity (IEC 947)</b>				
Number of conductors	1 or 2	1 or 2	2, 4 or 6	2, 4 or 6
Wire sizes	4 AWG to 500 kcmil	4 AWG to 500 kcmil	2/0 to 500 kcmil	2/0 to 500 kcmil
Type of connectors	Add-on lug kit	Add-on lug kit	Add-on lug kit	Add-on lug kit
<b>Control Wiring (12-Pin)</b>				
Wire sizes in AWG	22–14	22–14	22–14	22–14
Number of conductors (stranded)	2 (or one AWG 12)	2 (or one AWG 12)	2 (or one AWG 12)	2 (or one AWG 12)
Torque requirements in lb-in	3.5	3.5	3.5	3.5
Solid, stranded or flexible max. size in mm <sup>2</sup>	3.31	3.31	3.31	3.31
<b>Control Power Requirements</b>				
Voltage range (24V ±10%)	21.6–26.4	21.6–26.4	21.6–26.4	21.6–26.4
Steady-state current amps	1.0	1.0	1.4	1.4
Inrush current amps	10	10	10	10
Ripple	1%	1%	1%	1%
<b>Relays (1) Class A and C</b>				
Voltage AC—maximum	240	240	240	240
Voltage DC—maximum	120	120	120	120
Amps—maximum	3	3	3	3
<b>Environment</b>				
Temperature—operating	–30 to 50°C (no derating) consult factory for operation >50°C	–30 to 50°C (no derating) consult factory for operation >50°C	–30 to 50°C (no derating) consult factory for operation >50°C	–30 to 50°C (no derating) consult factory for operation >50°C
Temperature—storage	–50 to 70°C	–50 to 70°C	–50 to 70°C	–50 to 70°C
Altitude	<2000m—consult factory for operation >2000m	<2000m—consult factory for operation >2000m	<2000m—consult factory for operation >2000m	<2000m—consult factory for operation >2000m
Humidity	<95% noncondensing	<95% noncondensing	<95% noncondensing	<95% noncondensing
Operating position	Any	Any	Any	Any
Pollution degree IEC947-1	3	3	3	3
Impulse withstand voltage IEC947-4-1	6000V	6000V	6000V	6000V

**Note**

<sup>①</sup> U-Frame 500A unit does not have IEC certification.

## IT. Soft Starters—S801, continued

Description	S801 Soft Starter (Partial Catalog Number)				
	S801V50	S801V65	S801V72	S801V85	S801V10 <sup>①</sup>
Max. current capacity	500	650	720	850	1000
<b>Dimensions</b>					
Width in inches (mm)	11.03 (280.2)	11.03 (280.2)	11.03 (280.2)	11.03 (280.2)	11.03 (280.2)
Height in inches (mm)	16.57 (420.8)	16.57 (420.8)	16.57 (420.8)	16.57 (420.8)	16.57 (420.8)
Depth in inches (mm)	7.23 (183.7)	7.23 (183.7)	7.23 (183.7)	7.23 (183.7)	7.23 (183.7)
Weight in lbs (kg)	103 (46.8) with lugs 91 (41.4) without lugs	103 (46.8) with lugs 91 (41.4) without lugs	103 (46.8) with lugs 91 (41.4) without lugs	103 (46.8) with lugs 91 (41.4) without lugs	103 (46.8) with lugs 91 (41.4) without lugs
<b>General Information</b>					
Bypass mechanical lifespan	10M	10M	10M	10M	10M
Insulating voltage U <sub>i</sub>	660V	660V	660V	660V	660V
Ramp time range	0.5–180 seconds (0.5–360 seconds extended ramp)	0.5–180 seconds (0.5–360 seconds extended ramp)	0.5–180 seconds (0.5–360 seconds extended ramp)	0.5–180 seconds (0.5–360 seconds extended ramp)	0.5–180 seconds (0.5–360 seconds extended ramp)
Resistance to vibration	3g	3g	3g	3g	3g
Resistance to shock	15g	15g	15g	15g	15g
<b>Electrical Information</b>					
Operating voltage	200–600V	200–600V	200–600V	200–600V	200–600V
Operating frequency	47–63 Hz	47–63 Hz	47–63 Hz	47–63 Hz	47–63 Hz
Overload setting	30–100%	30–100%	30–100%	30–100%	30–100%
Trip class	5, 10, 20 and 30	5, 10, 20 and 30	5, 10, 20 and 30	5, 10, 20 and 30	5, 10, 20 and 30
<b>Cabling Capacity (IEC 947)</b>					
Number of conductors	2, 4 or 6	2, 4 or 6	2, 4 or 6	2, 4 or 6	2, 4 or 6
Wire sizes	2/0 to 500 kcmil	2/0 to 500 kcmil	2/0 to 500 kcmil	2/0 to 500 kcmil	2/0 to 500 kcmil
Type of connectors	Add-on lug kit	Add-on lug kit	Add-on lug kit	Add-on lug kit	Add-on lug kit
<b>Control Wiring (12-Pin)</b>					
Wire sizes in AWG	22–14	22–14	22–14	22–14	22–14
Number of conductors (stranded)	2 (or one AWG 12)	2 (or one AWG 12)	2 (or one AWG 12)	2 (or one AWG 12)	2 (or one AWG 12)
Torque requirements in lb-in	3.5	3.5	3.5	3.5	3.5
Solid, stranded or flexible max. size in mm <sup>2</sup>	3.31	3.31	3.31	3.31	3.31
<b>Control Power Requirements</b>					
Voltage range (24V ±10%)	21.6–26.4	21.6–26.4	21.6–26.4	21.6–26.4	21.6–26.4
Steady-state current amps	1.4	1.4	1.4	1.4	1.4
Inrush current amps	10	10	10	10	10
Ripple	1%	1%	1%	1%	1%
<b>Relays (1) Class A and C</b>					
Voltage AC—maximum	240	240	240	240	240
Voltage DC—maximum	120	120	120	120	120
Amps—maximum	3	3	3	3	3
<b>Environment</b>					
Temperature—operating	–30 to 50°C (no derating) consult factory for operation >50°C	–30 to 50°C (no derating) consult factory for operation >50°C	–30 to 50°C (no derating) consult factory for operation >50°C	–30 to 50°C (no derating) consult factory for operation >50°C	–30 to 50°C (no derating) consult factory for operation >50°C
Temperature—storage	–50 to 70°C	–50 to 70°C	–50 to 70°C	–50 to 70°C	–50 to 70°C
Altitude	<2000m—consult factory for operation >2000m	<2000m—consult factory for operation >2000m	<2000m—consult factory for operation >2000m	<2000m—consult factory for operation >2000m	<2000m—consult factory for operation >2000m
Humidity	<95% noncondensing	<95% noncondensing	<95% noncondensing	<95% noncondensing	<95% noncondensing
Operating position	Any	Any	Any	Any	Any
Pollution degree IEC947-1	3	3	3	3	3
Impulse withstand voltage IEC947-4-1	6000V	6000V	6000V	6000V	6000V

**Note**

① UL recognized component.

### Wiring Diagrams

#### Line Connected Soft Starter

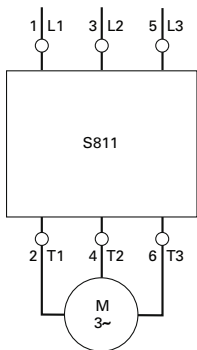

#### Inside-the-Delta Connected Soft Starter for a 6-Lead Motor

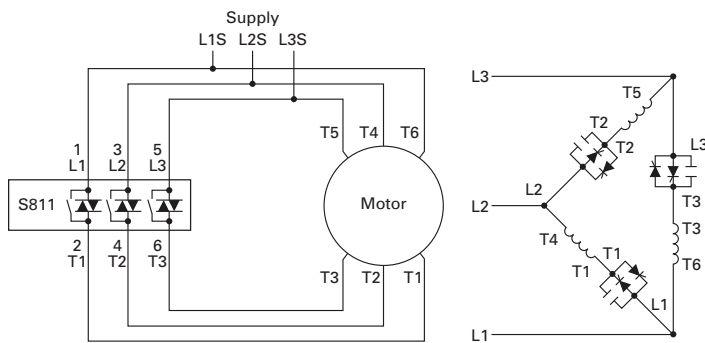

#### Inside-the-Delta Connected Soft Starter for a 12-Lead Low Voltage Motor

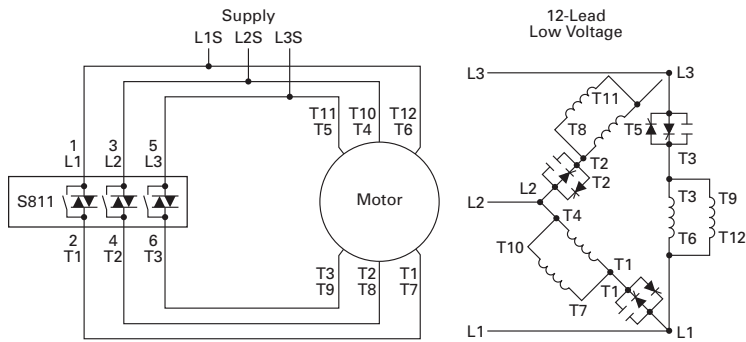

#### Inside-the-Delta Connected Soft Starter for a 12-Lead High Voltage Motor

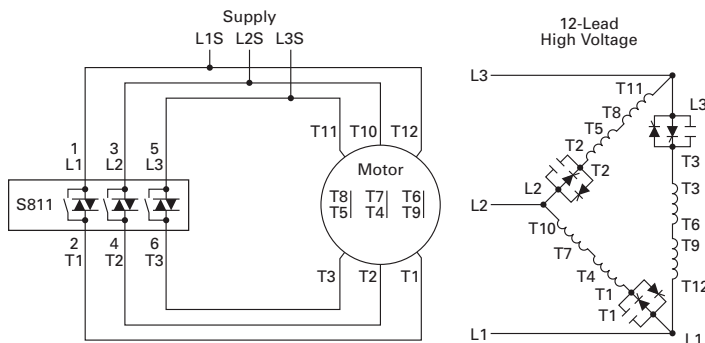

### Dimensions

Approximate Dimensions in Inches (mm)

#### II. Soft Starters—S801

Partial Catalog Number	W	H	D	Weight in Lbs (kg)
S801N37	2.60 (66.0)	7.38 (187.4)	6.63 (168.4)	5.8 (2.6)
S801N66	2.60 (66.0)	7.38 (187.4)	6.63 (168.4)	5.8 (2.6)
S801R10	4.37 (111.0)	7.92 (201.1)	7.03 (178.6)	10.5 (4.8)
S801R13	4.37 (111.0)	7.92 (201.1)	7.03 (178.6)	10.5 (4.8)
S801T18	7.65 (194.4)	12.71 (322.9)	6.69 (169.8)	48 (21.8) with lugs 41 (18.6) without lugs
S801T24	7.65 (194.4)	12.71 (322.9)	6.69 (169.8)	48 (21.8) with lugs 41 (18.6) without lugs
S801T30	7.65 (194.4)	12.71 (322.9)	6.69 (169.8)	48 (21.8) with lugs 41 (18.6) without lugs
S801U36	7.73 (196.3)	12.72 (323.1)	7.08 (179.9)	48 (21.8) with lugs 41 (18.6) without lugs
S801U42	7.73 (196.3)	12.72 (323.1)	7.08 (179.9)	48 (21.8) with lugs 41 (18.6) without lugs
S801U50	7.73 (196.3)	12.72 (323.1)	7.08 (179.9)	48 (21.8) with lugs 41 (18.6) without lugs
S801V36	11.03 (280.2)	16.57 (420.8)	7.23 (183.7)	103 (46.8) with lugs 91 (41.4) without lugs
S801V42	11.03 (280.2)	16.57 (420.8)	7.23 (183.7)	103 (46.8) with lugs 91 (41.4) without lugs
S801V50	11.03 (280.2)	16.57 (420.8)	7.23 (183.7)	103 (46.8) with lugs 91 (41.4) without lugs
S801V65	11.03 (280.2)	16.57 (420.8)	7.23 (183.7)	103 (46.8) with lugs 91 (41.4) without lugs
S801V72	11.03 (280.2)	16.57 (420.8)	7.23 (183.7)	103 (46.8) with lugs 91 (41.4) without lugs
S801V85	11.03 (280.2)	16.57 (420.8)	7.23 (183.7)	103 (46.8) with lugs 91 (41.4) without lugs
S801V10	11.03 (280.2)	16.57 (420.8)	7.23 (183.7)	103 (46.8) with lugs 91 (41.4) without lugs

Also refer to dimension drawings below and on Pages V6-T35-65 and V6-T35-66.

#### N-Frame (65 mm) S801

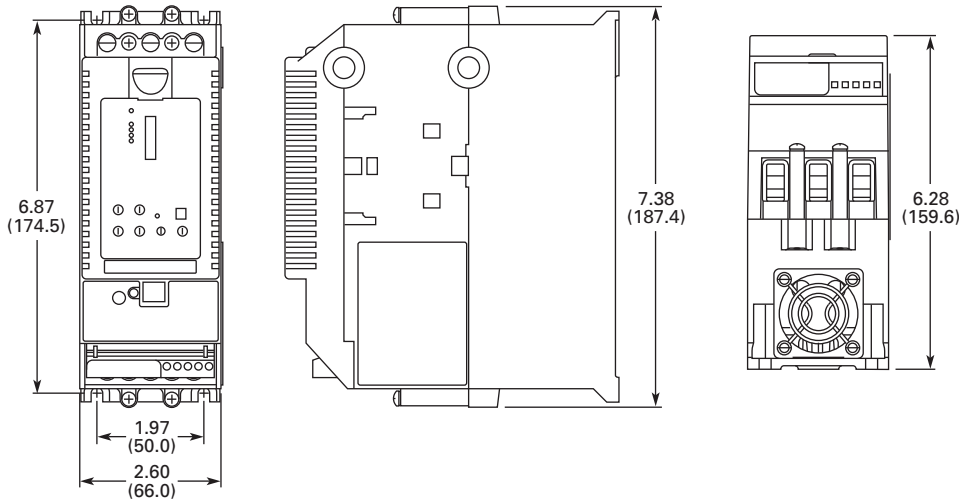



Approximate Dimensions in Inches (mm)

**R-Frame (110 mm) S801**

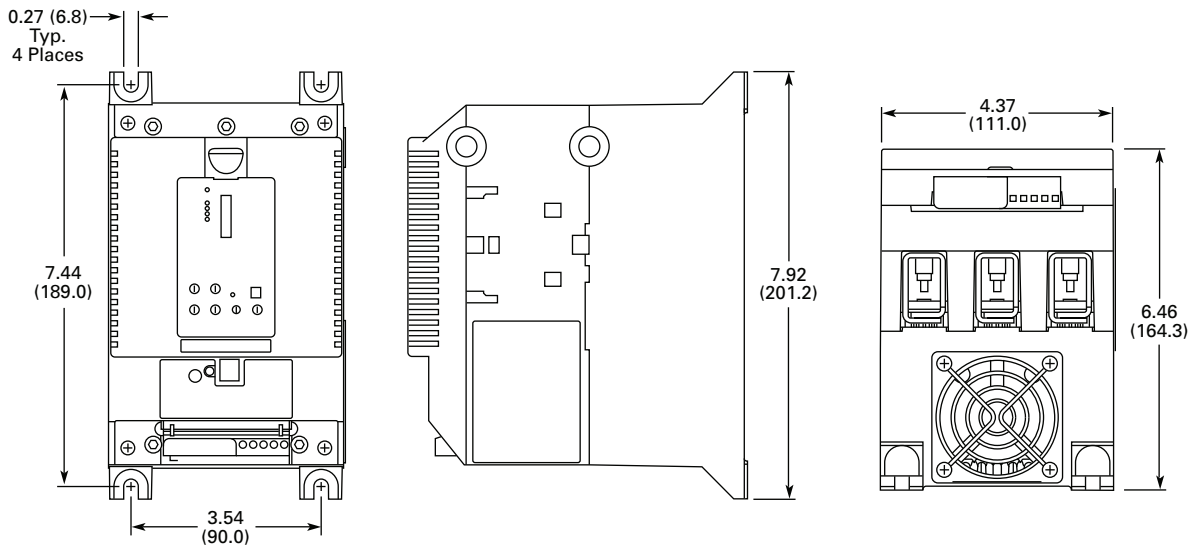

**T-Frame (200 mm) S801**

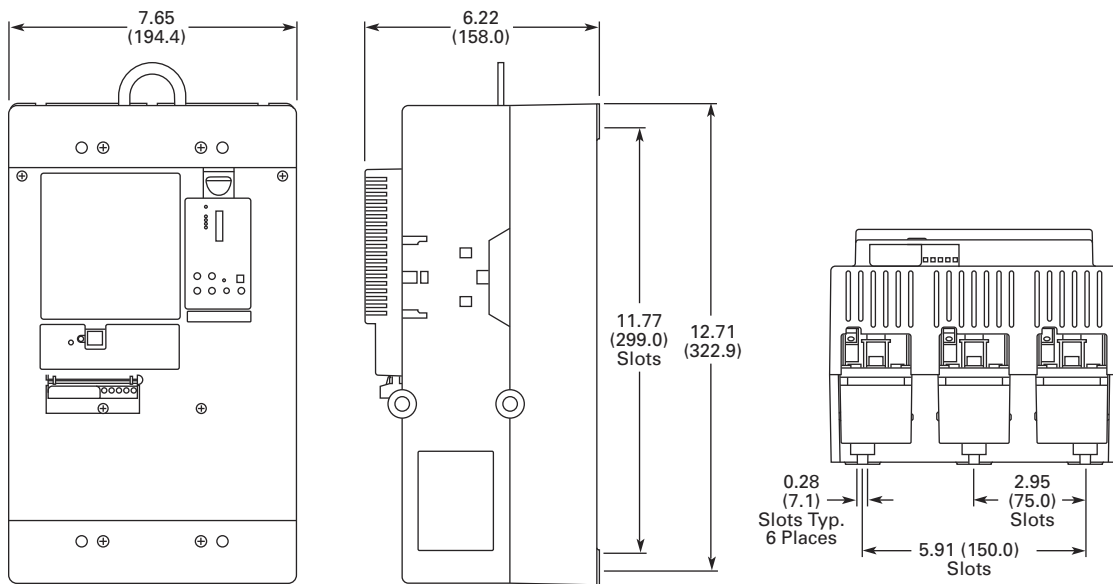

# 35.2

## Reduced Voltage Motor Starters

### Solid-State Starters

35

Approximate Dimensions in Inches (mm)

#### U-Frame (200 mm) S801

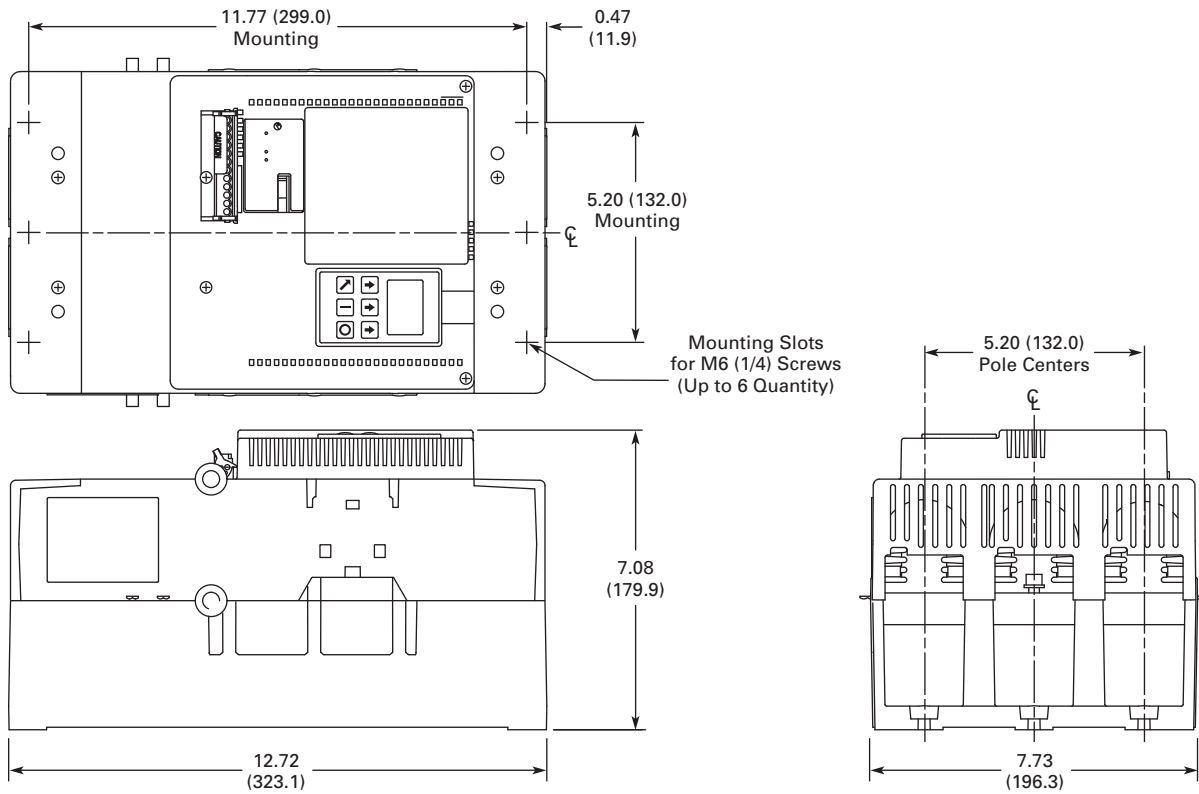

#### V-Frame (290 mm) S801

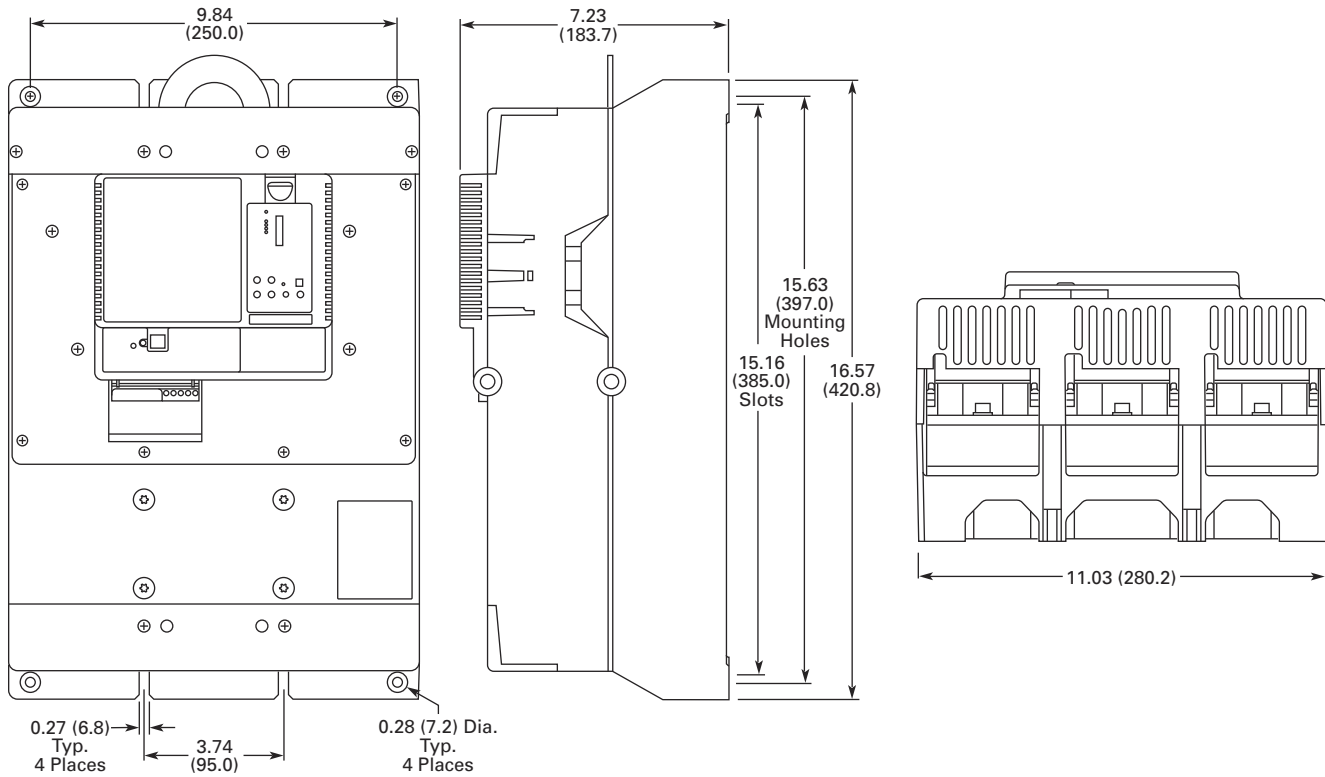

Type S811, Intelligent Technologies (IT) Soft Starters with DIM



### Contents

<b>Description</b>	<b>Page</b>
Type S801, Intelligent Technologies (IT) Soft Starters . . . . .	<b>V6-T35-39</b>
Type S811, Intelligent Technologies (IT) Soft Starters with DIM	
Operation . . . . .	<b>V6-T35-69</b>
Features and Benefits . . . . .	<b>V6-T35-72</b>
Standards and Certifications . . . . .	<b>V6-T35-75</b>
Instructional Leaflets . . . . .	<b>V6-T35-75</b>
Catalog Number Selection . . . . .	<b>V6-T35-75</b>
Product Selection . . . . .	<b>V6-T35-76</b>
Accessories . . . . .	<b>V6-T35-90</b>
Options . . . . .	<b>V6-T35-91</b>
Technical Data and Specifications . . . . .	<b>V6-T35-92</b>
Wiring Diagrams . . . . .	<b>V6-T35-96</b>
Dimensions . . . . .	<b>V6-T35-97</b>

## Type S811, Intelligent Technologies (IT) Soft Starters with DIM

### Product Description

Eaton's *IT*. S811 offers all the popular features of the S801, but adds enhanced functionality with the new DIM (Digital Interface Module), communications, metering, monitoring and diagnostics capabilities.

Eaton's Intelligent Technologies (*IT*) Line of S811 Reduced Voltage Soft Starters is very compact, multi-functional, easy to install and easy to set operating parameters. Designed to control the acceleration and deceleration of three-phase motors up to 690V, the line is available from 11–1000A.

The S811 is designed to be a complete package combining the silicon controlled rectifiers (SCRs), bypass contactor and overload in one, very compact unit. The S811 is available as a component for panel mounting, in motor control centers or in enclosed control (NEMA Type 1, 3R, 4, 4X, 7/9 and 12).

### Application Description

Designed to control the acceleration and deceleration of three-phase motors, the *IT*. S811 Soft Starter uses SCRs to control the voltage to soft start and soft stop the motor. After the motor is started, internal run bypass contactors close, resulting in the motor running directly across-the-line. The built-in solid-state overload protects the motor from overload conditions with sophisticated algorithms that model true motor heating, resulting in better motor protection and fewer nuisance trips. Advanced protective and diagnostic features reduce downtime.

A voltage ramp start or current limit start is available. Kick start is available in either starting mode. The soft stop option allows for a ramp stop time that is longer than the coast to stop time. The pump control option provides a smooth transition for starting and stopping a motor and eliminating the "water-hammer" effect that can damage pipes, valves and pumps.

The S811 offers an impressive array of advanced protective features. Not only are the protective features selectable, but many offer variable settings and adjustable time delays to ride through system discrepancies.

The S811 has an easy to use Digital Interface Module (DIM) that allows the user to configure the device and to read system parameters and monitor system values. The DIM includes an LCD display and keypad to scroll through the various menus. The DIM allows the user to modify control parameters, enable or disable protections, set communication variables, monitor system parameters such as line voltages and currents, and access the fault queue.

The DIM can be removed from the S811 and remote mounted. Kits are available to door mount the DIM, enabling users to safely configure, commission, monitor and troubleshoot the system at the electrical panel without opening the enclosure door. This will help eliminate the possibility of an arc flash incident.

### Digital Interface Module (DIM)

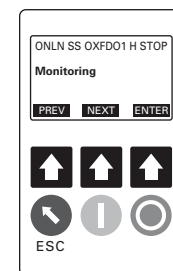

# 35.2

## Reduced Voltage Motor Starters

### Solid-State Starters

35

#### Communications

The S811 has built-in communication capabilities through Eaton's QC (Quick Connect) Port. QCPort™ enables the soft starter to be connected to a variety of networks, including DeviceNet™, EtherNet/Modbus, EtherNet/IP and PROFIBUS. The advantage of QCPort is that multiple control components can be connected to one Eaton **IT**. D77D gateway.

The gateway concentrates data from the devices into a single node. Configuration is simple—a single press of the gateway's Auto Configuration button sets the system up for default operation. This automatically configures the I/O assemblies to the QCPort system devices. The data from these devices are then assembled into single input and output messages

The S811 communication parameters can be configured with the DIM or through the fieldbus using CH Studio Component Manager. Advanced communication configuration settings provide the system integrator with powerful tools to facilitate system optimization

#### Communications Reference

Description	Part Number
DeviceNet network adapter	D77D-DNA
EtherNet Modbus network adapter	D77D-EMA
EtherNet/IP network adapter	D77D-EIP
PROFIBUS network adapter	D77D-PNA
Terminator and power tap	D77E-QPLR
DIN rail communications backplane, 7-position	D77E-BP7
DIN rail communications backplane, 12-position	D77E-BP12
85–264 Vac input, 24 Vdc output	PSG240E
360–575 Vac input, 24 Vdc output	PSG240F

#### S811 Connection

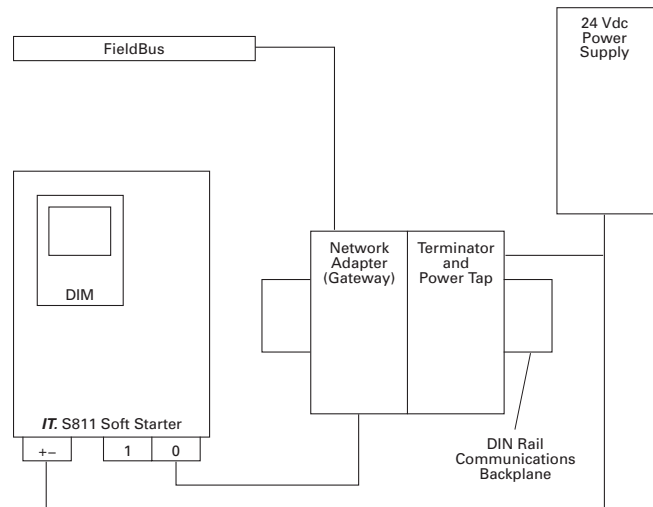

### Operation

#### Starting and Stopping Modes

The S811 has a variety of starting and stopping methods to provide superior performance in the most demanding applications. The motor can be started in either voltage ramp start or current limit start mode. Kick start and soft stop are available within both starting modes.

#### Voltage Ramp Start

Provides a voltage ramp to the motor resulting in a constant torque increase. The most commonly used form of soft start, this start mode allows you to set the initial torque value and the duration of the ramp to full voltage conditions. Bypass contactors close after ramp time.

- Adjustable initial torque 0–85% of locked rotor torque
- Adjustable ramp time 0.5–180 seconds (can be extended with factory modification)

#### Starting Characteristics—Ramp Start

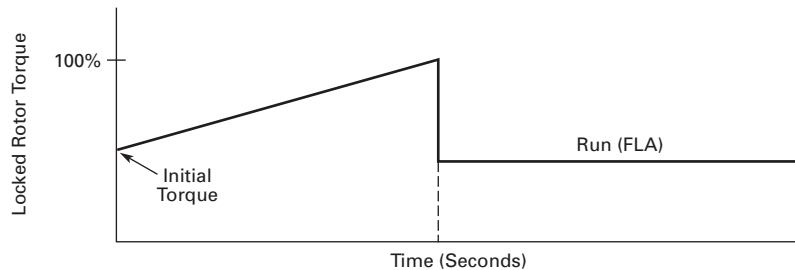

#### Current Limit Start

Limits the maximum current available to the motor during the start phase. This mode of soft starting is used when it becomes necessary to limit the maximum starting current due to long start times or to protect the motor. This start

mode allows you to set the maximum starting current as a percentage of locked rotor current and the duration of the current limit. Bypass contactors close after current limit time.

- Maximum current of 0–85% locked rotor current
- Adjustable ramp time 0.5–180 seconds (can be extended with factory modification)

#### Starting Characteristics—Current Limit Start

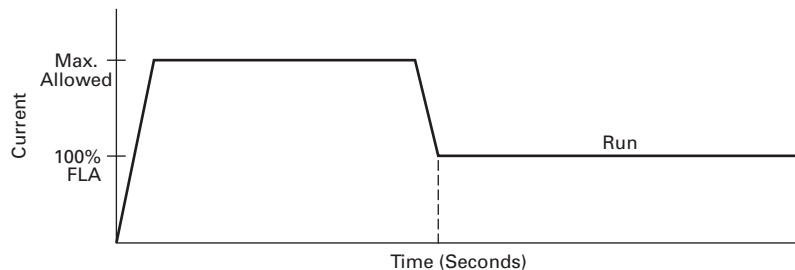

**Kick Start**

Selectable feature in both voltage ramp start and current limit start modes. Provides a current and torque “kick” for 0 to 2.0 seconds. This provides greater initial current to develop additional torque to breakaway a high friction load.

- 0–85% of locked rotor torque
- 0–2.0 seconds duration

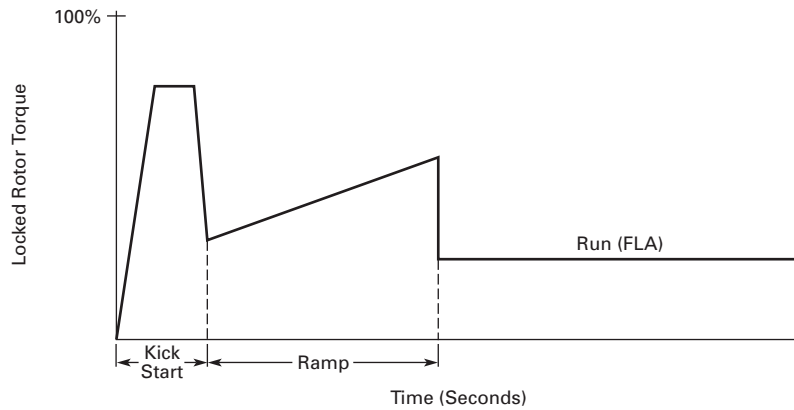
**Starting Characteristics—Kick Start****Soft Stop**

Allows for a controlled stopping of a load. Used when a stop-time that is greater than the coast-to-stop time is desired. Often used with high friction loads where a sudden stop may cause system or load damage.

- Stop time = 0–60 seconds

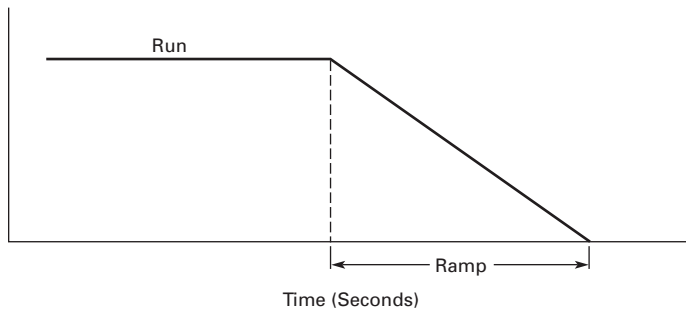
**Starting Characteristics—Soft Stop**

**Edge and Level Sensing Control****Edge Sensing**

Edge sensing requires +24 Vdc power be momentarily applied to Pin 1 (with terminal P at +24 Vdc) to initiate a start under all conditions. After a stop or fault occurs, the +24 Vdc must be removed, then reapplied to pin 1 before another start can occur. This control configuration should be used when restarting of the motor after a fault or stop must be supervised manually or as a part of a control scheme. The cycling of +24 Vdc power to Terminal 1 before starting is required regardless of the position of the auto reset switch on the DIM.

**Level Sensing**

Level sensing will enable a motor to restart after a fault is cleared without cycling +24 Vdc power to Terminal 1 as long as:

- Terminal P is supplied with +24 Vdc (to start from Terminal Block, Input #3 must also be enabled)
- The auto reset switch on the DIM is set to enabled
- All faults have been reset

This control configuration should be used where it is desirable to restart a motor after a fault without additional manual or automatic control. An example of this condition would be on a remote pumping station where it is desirable to automatically restart a pump after a power outage without operator intervention.

**Note:** If the auto reset feature is used, CAUTION must be exercised to ensure that any restart occurs in a safe manner.

**Features and Benefits**

- Communication capabilities with various protocols
- The DIM (Digital Interface Module) provides an intuitive, easy-to-use human interface with powerful configuration capabilities to maximize system performance
- Door or device mounted DIM enables users to safely configure, commission, monitor and troubleshoot the system at the electrical panel without opening the enclosure door, eliminating the possibility of an arc flash incident
- System operating parameters can be monitored enterprise-wide through a communications network. Increase uptime by providing data for process management and preventive diagnostics
- Run internal bypass mode greatly reduces internal heating created by the greater power dissipation in the SCRs. Bypass contactor directly connects the motor to the line and improves system efficiency by reducing internal power losses
- Internal solid-state overload protection provides accurate current measurement and trip settings. Sophisticated algorithms solve a series of differential equations that model true motor heating and cooling, resulting in superior motor overload protection while minimizing nuisance trips. Advanced selectable protective features safeguard the motor and system against a variety of system faults
- Internal run bypass contactors and overload protection eliminate the need for additional devices, reducing enclosure sizes, minimizing installation and wiring time, and reducing overall assembly size and cost
- Wide range of overload FLA settings (31–100% of rated current) and a selectable trip class (5–30) offers users the flexibility to fine tune the starter to match specific application requirements
- Variable ramp times and torque control settings provide unlimited starting configurations, allowing for maximum application flexibility
- Kick-start feature enables soft starting of high friction loads
- Soft stop control for applications where an abrupt stop of the load is not acceptable
- Pump control option with sophisticated pump algorithms on both starting and stopping that minimize the pressure surges that cause water hammer. The pump control option will maximize the life of the pump and piping systems while minimizing the downtime caused by system failure
- Six SCRs control all three motor phases, providing smooth acceleration and deceleration performance
- Soft acceleration and deceleration reduces wear on belts, gears, chains, clutches, shafts and bearings
- Reduce the peak inrush current's stress on the power system
- Manage peak starting torque to diminish mechanical system wear and damage
- 24 Vdc control voltage enhances personnel and equipment safety
- Removable, lockable control terminal block reduces maintenance costs. Also provides the opportunity for OEMs to reduce assembly and test costs by utilizing pre-assembled wire harnesses

**Protective Features**

All protective features can be configured, enabled or disabled with the DIM or through the communications network.

**Motor Overload**

The S811 includes electronic overload protection as standard. The overload meets applicable requirements for a motor overload protective device. The overload protects the motor from over heat conditions with the use of sophisticated algorithms that model true motor heating, resulting in superior motor protection and fewer nuisance trips.

The S811 calculates a thermal memory value based on the heat energy introduced into the motor during the start process. A 100% value represents the maximum safe internal temperature of the motor.

When the thermal memory value reaches 100%, an overload trip will occur removing power to the motor. Upon trip, the S811 stores the calculated motor heating value and will not allow a motor re-start until the motor has a thermal memory value of less than 100%. This feature ensures the motor will not be damaged by repeated overload trip, reset and re-start cycles.

The thermal memory value can be monitored through the DIM or the communications network. The thermal memory value can be of great use in determining an impending overload trip condition. Alarms can be implemented in the

process monitoring system warning of an impending trip before a trip occurs halting the process. Costly system downtime can be avoided.

The trip current is adjusted to match the specific application requirements by entering the motor nameplate full load current rating and trip class. The FLA parameter is adjustable from 32% to 100% of the unit's rated current. The overload trip class is adjustable from class 5 through class 30. The overload is ambient temperature compensated—meaning its trip characteristics will not vary with changes in ambient temperature. The overload protection can be enabled, disabled, or disabled on start.

**Short Circuit**

The use of a short-circuit protective device in coordination with the S811 is required in branch motor circuits by most electrical codes. Short-circuit coordination ratings with both fuses and Eaton molded case circuit breakers are available providing customers with design flexibility. The S811 has short-circuit coordination ratings as an open component, an enclosed starter, and in a motor control center.



**Jam**

Excessive current and torque up to locked rotor levels can occur in a jam condition. The condition can result in stress and damage to the motor, load, mechanical system, and the electrical distribution system. Jam protection prevents the stress and damage from a jam during normal run. After the motor is in bypass, a current greater than 300% FLA setting will cause the starter to trip on a jam fault.

**Stall**

Excessive current and torque up to locked rotor levels can occur in a stall condition. The condition can lead to an overload trip and result in stress and damage to the motor, load, mechanical system, and the electrical distribution system. Stall protection prevents stress and damage to a motor that has not come up to speed during the soft start time. The S811 will trip to protect the system in the event that the motor did not get to the rated speed in the defined soft start period. A current greater than 200% FLA at the end of the soft start period will cause the starter to trip on a stall fault.

**Pole Over Temperature**

High ambient temperatures, extended ramp times and high duty cycle conditions may cause the S811 power pole conductors to reach a temperature that exceeds their thermal rating. The S811 is equipped with sensors that monitor the temperature of the power poles. Over temperature protection occurs if the power pole's thermal capacity is exceeded. The soft starter will trip in over temperature conditions, preventing device failure.

Each power pole temperature value can be monitored through the DIM or the communications network. This feature can be of use in determining an impending over temperature trip condition.

When using a communications network, alarms can be implemented in the process monitoring system warning of an impending trip before the trip occurs, halting the process.

**Phase Loss**

Loss of a phase can cause a significant increase in the current drawn in the remaining two phases. Phase loss can lead to motor damage before an eventual overload trip occurs. Phase loss is typically an indication of a failure in the electrical distribution system. The S811 will detect a phase loss and trip if any phase current drops below a preset value. The phase loss trip level is adjustable from 0% to 100% of the average of the other two phase levels with an adjustable trip delay of 0.1 to 60 seconds.

**Phase Imbalance**

Phase current or voltage imbalance can cause a significant increase in the current drawn in the remaining two phases. Phase imbalance can lead to motor damage before an eventual overload trip. Phase imbalance is typically an indication of a failure in the electrical distribution system or the motor. The S811 will detect both current and voltage phase imbalances and trip if any phase becomes imbalanced as compared to the average of the other two phases.

The phase current imbalance trip level is adjustable from 0% to 100% of the average of the current in the other two phases with an adjustable trip delay of 0.1 to 60 seconds.

The phase voltage imbalance trip level is adjustable from 0% to 100% of the average of the voltage in the other two phases with an adjustable trip delay of 0.1 to 60 seconds.

**Reset Mode**

The S811 can be set up for automatic or manual reset on trip. The manual reset mode requires the operator to physically press the RESET button located on the Soft Starter. The trip can be manually reset through the DIM or through the communications network. The trip can also be electrically reset by energizing a 24 Vdc input on the control terminal block.

The automatic reset mode allows the Soft Starter to be automatically reset as soon as the trip condition is no longer present. With the automatic reset mode, after the fault is no longer present, the motor will be restarted as soon as a valid start signal is present.

**Phase Reversal**

The S811 can determine if the proper line phase sequence is present by default. The device will trip if the line phase sequence is something other than A-B-C. The S811 can be configured to operate under reversed phase conditions (A-C-B).

**Shorted SCR Detection**

The S811 monitors the operation of the power poles and will trip under a shorted SCR condition.

**Open SCR Detection**

The S811 monitors the operation of the power poles and will trip under an open SCR condition.

**Low Current**

Low current conditions can be a result of a loss of load or a failure in the mechanical system. The S811 has low current protection that will trip if the average rms current falls below a preset value. The low current protection can be programmed as a percent of motor FLA from 0% to 100%.

**Low Voltage**

Low voltage conditions can result from disturbances in the electrical power distribution system. Low voltage conditions can cause a malfunction and damage to electrical equipment. The S811 has low voltage protection that will trip if the average rms voltage falls below a preset value. The low voltage protection can be programmed as a percent of nominal voltage from 1% to 99% with a trip delay of 0.1 to 60 seconds to accommodate short temporary voltage drops during the start process.

**High Voltage**

High voltage conditions can result from disturbances in the electrical power distribution system. High voltage conditions can cause malfunctions or failures of electrical equipment. The S811 has high voltage protection that will trip if the average rms voltage is greater than a preset value. The high voltage protection can be programmed as a percent of nominal voltage from 101% to 120% with a trip delay of 0.1 to 60 seconds.

**Monitoring Capabilities**

The S811 has an impressive array of system monitoring capabilities that allows users to access real time process and diagnostic data. This data can be viewed at the device with the DIM or through a communications network. Data over a communications network can provide valuable insight into the condition of the equipment and processes. Maintenance and

production personnel can monitor critical operational and maintenance data from a central control station that can be located far away from the production facility. Process data can be monitored to determine system anomalies that may indicate a need for preventive maintenance or an impending failure. Adjustments made through the communications

network can reduce costs by minimizing the time traveling to the location where the motor controls are located. When faults do occur, real time fault data can assist maintenance in troubleshooting and planning repair resources. Remote reset signals can be given to tripped devices without the need for manual intervention by maintenance personnel.

**Average Line Current**

Provides the average of the three-phase rms line currents in amps, accurate to within 2%. Current data can be used to indicate a need for maintenance. Increased currents in a fixed load application can indicate a reduction in system efficiencies and performance, signifying system maintenance is due.

**Average Pole Current**

Provides the average of the three-phase rms pole currents in amps, accurate to within 2%. The pole current is the current through the Soft Starter. The line and pole current will be identical in inline applications, and will differ in inside-the-delta applications.

**Average Line Current as a % FLA**

Provides the average rms line current as a percentage of the S811 FLA setting.

**Three-Phase Line Currents**

Provides three rms phase line currents in amps, accurate to within 2%. Imbalances or changes in the relative phase current to one another can indicate anomalies in the motor or electrical distribution system.

**Three-Phase Pole Currents**

Provides three rms phase pole currents in amps, accurate to within 2%. The pole current is the current through the soft starter. The line and pole current will be identical in in-line applications, and will differ in inside-the-delta applications.

**Three-Phase Line Voltages**

Provides the individual rms three-phase line voltages. Imbalances or changes in the relative phase voltage to one another can indicate anomalies in the motor or electrical distribution system. Voltage can be used to monitor electrical distribution system performance. Warnings, alarms and system actions to low or high voltage conditions can be implemented.

**Percent Thermal Memory**

Provides the real time calculated thermal memory value. The S811 calculates thermal memory value. A 100% value represents the maximum safe internal temperature of the motor. When the thermal memory value reaches 100%, an overload trip will occur, removing power to the motor.

The thermal memory value can be of great use in determining an impending overload trip condition. When using a communications network, alarms can be implemented in the process monitoring system warning of an impending trip before the trip occurs, halting the process. Costly system downtime can be avoided.

**DC Control Voltage**

Monitors level of the 24 Vdc control voltage. Fluctuations in control voltage can cause component malfunction and failure. System control voltage data can be used to implement warnings, alarms and system actions to low or high voltage conditions.

**Pole Temperature**

Increases in power pole temperature are caused by increases in ambient temperature, start/stop times and start duty cycles. Changes in pole temperatures represent a change in system operating conditions. Identifying unexpected operating conditions or changes can prompt maintenance and aid in process evaluation activities.

**PCB Device Temperature**

An increase in printed circuit board (device) temperature is a strong indication of an increase in ambient temperature. High ambient temperature operation can be identified with the device temperature data. Device temperature increases can be due to undersized enclosures, failure of cooling fans or blocked venting. High operating temperatures will reduce the life of all electrical equipment in the enclosure.

**Start Count**

Start count data can be used to monitor system output, schedule preventative maintenance, identify system anomalies and identify changes in system operation.

### Diagnostics

#### Fault Queue

Current fault and a fault queue containing the last nine system faults can be read through the DIM or communications network. Fault identification can minimize troubleshooting time and cost, and prevent arc flash incidents. The fault queue can be remotely accessed through a communications network to assist in planning maintenance resources. Thirty different faults can be identified by the S811.

#### Control Status

The S811 provides data that represents system conditions that can be read through the DIM or the communications network. This data identifies the status of the system and the control commands the system is requesting of the S811. This can be used for advanced troubleshooting and system integration activities.

#### Breaker Status

The S811 has provisions to read and display circuit breaker status. Eaton communicating cover control or other communicating protective device is required to take advantage of this feature.

#### Standards and Certifications

- IEC 60947-4-2
- EN 60947-4-2
- UL listed (NMFT-E202571) Frame N37 to V85
- UL recognized (NMFT2)–Frame V10
- CE marked
- CSA certified (3211 06)
- CSA elevator (2411 01)



#### Instructional Leaflets

- User manual MN03902002E
- Inside-the-Delta user manual MN03902009E
- Outline drawings:
  - 65 mm, N-Frame: 10-8574
  - 110 mm, R-Frame: 10-8575
  - 200 mm, T-Frame: 10-8576
  - 200 mm, U-Frame: 10-8857
  - 290 mm, V-Frame: 10-8577

### Catalog Number Selection

#### S811 Open Soft Starters ①

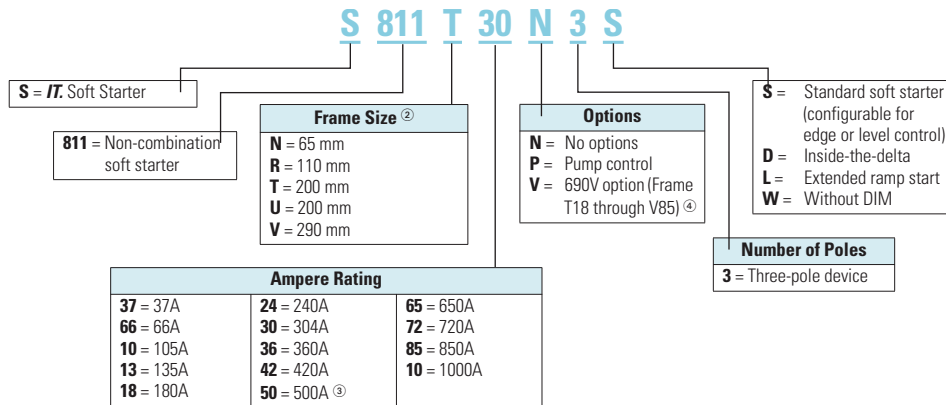

#### Notes

- ① All units require a 24 Vdc power supply found on catalog Page V6-T35-90, or equivalent.
- ② T-, U- and V-Frames require lug kits found on Page V6-T35-90.
- ③ U-Frame 500A unit does not have IEC certification.
- ④ Not available in U-Frame.

### Product Selection

#### Standard Duty Ratings

Starting Method	Ramp Current % of FLA	Ramp Time Seconds	Starts per Hour	Ambient Temperature
Soft start	300%	30 sec.	3	50°C
Full voltage	500%	10 sec.	3	50°C
Wye-delta	350%	20 sec.	3	50°C
80% RVAT	480%	20 sec.	2	50°C
65% RVAT	390%	20 sec.	3	50°C
50% RVAT	300%	20 sec.	4	50°C

Motor applications and customer needs come in many different varieties. With the standard and severe duty rating tables, we have attempted to provide

guidelines on what the **IT** Soft Starter is capable of. If the application falls under these categories, you can use these charts. For other applications, or when a

question arises, consult with your local Eaton representative or call our Technical Resource Center.

S811



#### Standard Duty—15 Second Ramp, 4 Starts per Hour, 300% Current Limit at 40°C

Max. Current	Three-Phase Motors kW Rating (50 Hz)			hp Rating (60 Hz)				575–690V <sup>①</sup>				Catalog Number
	230V	380–400V	440V	200V 1.0SF	1.15SF	230V 1.0SF	1.15SF	460V 1.0SF	1.15SF	1.0SF	1.15SF	
<b>Frame Size N</b>												
37	10	18.5	18.5	10	10	10	10	25	20	30	30	<b>S811N37N3S</b>
66	18.5	30	37	20	15	20	20	50	40	60	50	<b>S811N66N3S</b>
<b>Frame Size R</b>												
105	30	55	59	30	25	40	30	75	60	100	75	<b>S811R10N3S</b>
135	40	63	80	40	30	50	40	100	75	125	100	<b>S811R13N3S</b>
<b>Frame Size T</b>												
180	51	90	110	60	50	60	60	150	125	150	150	<b>S811T18N3S</b>
240	75	110	147	75	60	75	75	200	150	200	200	<b>S811T24N3S</b>
304	90	160	185	100	75	100	100	250	200	300	250	<b>S811T30N3S</b>
<b>Frame Size U</b>												
360	110	185	220	125	100	150	125	300	250	350	300	<b>S811U36N3S</b>
420	129	220	257	150	125	175	150	350	300	450	350	<b>S811U42N3S</b>
500	150	257	300	150	150	200	150	400	350	500	450	<b>S811U50N3S<sup>②</sup></b>
<b>Frame Size V</b>												
360	110	185	220	125	100	150	125	300	250	350	300	<b>S811V36N3S</b>
420	129	220	257	150	125	175	150	350	300	450	350	<b>S811V42N3S</b>
500	150	257	300	150	150	200	150	400	350	500	450	<b>S811V50N3S</b>
650	200	355	425	250	200	250	200	500	450	600	500	<b>S811V65N3S</b>
720	220	400	450	—	—	300	250	600	500	700	600	<b>S811V72N3S</b>
850	257	475	500	—	—	350	300	700	600	900	700	<b>S811V85N3S</b>
1000	277	525	550	—	—	400	350	800	700	900	800	<b>S811V10N3S<sup>③</sup></b>

For **Pump Option**, replace character **8** with **“P”** and also, see **Page V6-T35-91**.

#### Notes

- ① 690V is available only from T18 thru V85. Not available on U-Frames.
- ② 500A rating does not have IEC certification.
- ③ For more information on optimum performance of the 1000A Frame Size V S811, see Appendix E of MN03902002E.

S811



### Standard Duty—25 Second Ramp, 4 Starts per Hour, 300% Current Limit at 40°C

Max. Current	Three-Phase Motors kW Rating (50 Hz)			hp Rating (60 Hz)		230V		460V		575–690V <sup>①</sup>		Catalog Number
	230V	380–400V	440V	200V 1.0SF	1.15SF	1.0SF	1.15SF	1.0SF	1.15SF	1.0SF	1.15SF	
<b>Frame Size N</b>												
34	9	15	18.5	10	7-1/2	10	10	25	20	30	25	<b>S811N37N3S</b>
63	15	30	33	20	15	20	20	40	40	60	50	<b>S811N66N3S</b>
<b>Frame Size R</b>												
96	25	45	55	30	25	30	30	75	60	75	75	<b>S811R10N3S</b>
120	33	63	63	40	30	40	40	75	75	100	100	<b>S811R13N3S</b>
<b>Frame Size T</b>												
150	45	80	90	50	40	50	50	100	100	150	125	<b>S811T18N3S</b>
215	63	110	132	60	60	75	60	150	150	200	150	<b>S811T24N3S</b>
278	80	147	160	75	75	100	75	200	200	250	250	<b>S811T30N3S</b>
<b>Frame Size U</b>												
320	90	160	185	100	75	125	100	250	200	300	250	<b>S811U36N3S</b>
380	110	200	220	125	100	150	125	300	250	350	300	<b>S811U42N3S</b>
460	140	250	280	150	125	150	150	350	300	450	400	<b>S811U50N3S<sup>②</sup></b>
<b>Frame Size V</b>												
320	90	160	185	100	75	125	100	250	200	300	250	<b>S811V36N3S</b>
380	110	200	220	125	100	150	125	300	250	350	300	<b>S811V42N3S</b>
460	140	250	280	150	125	150	150	350	300	450	400	<b>S811V50N3S</b>
610	185	315	375	250	150	200	200	500	450	600	500	<b>S811V65N3S</b>
680	200	375	445	—	200	250	200	600	500	700	600	<b>S811V72N3S</b>
810	250	450	500	—	—	300	300	700	600	900	700	<b>S811V85N3S</b>
890	290	510	560	—	—	400	350	700	600	900	700	<b>S811V10N3S<sup>③</sup></b>

For **Pump Option**, replace character **8** with **“P”** and also, see **Page V6-T35-91**.

**Notes**

- ① 690V is available only from T18 thru V85. Not available on U-Frames.
- ② 500A rating does not have IEC certification.
- ③ For more information on optimum performance of the 1000A Frame Size V S811, see Appendix E of MN03902002E.

S811



**Standard Duty—15 Second Ramp, 4 Starts per Hour, 300% Current Limit at 50°C**

Max. Current	Three-Phase Motors kW Rating (50 Hz)			hp Rating (60 Hz)				575–690V <sup>①</sup>				Catalog Number
	230V	380–400V	440V	200V 1.0SF	1.15SF	230V 1.0SF	1.15SF	460V 1.0SF	1.15SF	1.0SF	1.15SF	
<b>Frame Size N</b>												
34	9	15	18.5	10	7-1/2	10	10	25	20	30	25	<b>S811N37N3S</b>
63	15	30	33	20	15	20	20	40	40	60	50	<b>S811N66N3S</b>
<b>Frame Size R</b>												
96	25	45	55	30	25	30	30	75	60	75	75	<b>S811R10N3S</b>
120	33	63	63	40	30	40	40	75	75	100	100	<b>S811R13N3S</b>
<b>Frame Size T</b>												
150	45	80	90	50	40	50	50	100	100	150	125	<b>S811T18N3S</b>
215	63	110	132	60	60	75	60	150	150	200	150	<b>S811T24N3S</b>
278	80	147	160	75	75	100	75	200	200	250	250	<b>S811T30N3S</b>
<b>Frame Size U</b>												
320	90	160	185	100	75	125	100	250	200	300	250	<b>S811U36N3S</b>
460	110	200	220	125	100	150	125	300	250	350	300	<b>S811U42N3S</b>
460	140	250	280	150	125	150	150	350	300	450	400	<b>S811U50N3S<sup>②</sup></b>
<b>Frame Size V</b>												
320	90	160	185	100	75	125	100	250	200	300	250	<b>S811V36N3S</b>
380	110	200	220	125	100	150	125	300	250	350	300	<b>S811V42N3S</b>
460	140	250	280	150	125	150	150	350	300	450	400	<b>S811V50N3S</b>
610	185	315	375	250	150	200	200	500	450	600	500	<b>S811V65N3S</b>
680	200	375	445	—	200	250	200	600	500	700	600	<b>S811V72N3S</b>
830	257	450	500	—	—	300	300	700	600	900	700	<b>S811V85N3S</b>
960	302	510	540	—	—	350	300	800	700	900	800	<b>S811V10N3S<sup>③</sup></b>

For **Pump Option**, replace character **8** with **“P”** and also, see **Page V6-T35-91**.

**Notes**

- ① 690V is available only from T18 thru V85. Not available on U-Frames.
- ② 500A rating does not have IEC certification.
- ③ For more information on optimum performance of the 1000A Frame Size V S811, see Appendix E of MN03902002E.

S811



### Standard Duty—50 Second Ramp, 2 Starts per Hour, 300% Current Limit at 50°C

Max. Current	Three-Phase Motors kW Rating (50 Hz)			hp Rating (60 Hz)				575–690V <sup>①</sup>				Catalog Number
	230V	380–400V	440V	200V 1.0SF	1.15SF	230V 1.0SF	1.15SF	460V 1.0SF	1.15SF	1.0SF	1.15SF	
<b>Frame Size N</b>												
21	5.5	10	11	5	5	5	5	15	10	15	15	<b>S811N37N3S</b>
42	11	18.5	22	10	10	15	10	30	25	40	30	<b>S811N66N3S</b>
<b>Frame Size R</b>												
60	15	30	33	15	15	20	15	40	40	50	50	<b>S811R10N3S</b>
80	22	40	45	25	20	30	25	60	50	75	60	<b>S811R13N3S</b>
<b>Frame Size T</b>												
115	33	59	63	30	30	40	30	75	75	100	100	<b>S811T18N3S</b>
150	45	80	90	50	40	50	50	100	100	150	125	<b>S811T24N3S</b>
192	55	100	110	60	50	60	60	150	125	200	150	<b>S811T30N3S</b>
<b>Frame Size U</b>												
280	80	150	160	75	75	100	75	200	200	250	250	<b>S811U36N3S</b>
340	110	180	200	100	100	125	100	250	200	350	300	<b>S811U42N3S</b>
380	110	200	220	125	100	150	125	300	250	350	300	<b>S811U50N3S<sup>②</sup></b>
<b>Frame Size V</b>												
280	80	150	160	75	75	100	75	200	200	250	250	<b>S811V36N3S</b>
340	110	180	200	100	100	125	100	250	200	350	300	<b>S811V42N3S</b>
380	110	200	220	125	100	150	125	300	250	350	300	<b>S811V50N3S</b>
420	129	220	257	150	125	150	150	350	300	450	350	<b>S811V65N3S</b>
480	147	257	295	150	150	200	150	400	350	500	450	<b>S811V72N3S</b>
590	180	315	375	200	150	200	200	500	400	600	500	<b>S811V85N3S</b>
650	205	370	415	250	200	250	200	500	450	600	500	<b>S811V10N3S<sup>③</sup></b>

For **Pump Option**, replace character **8** with **“P”** and also, see **Page V6-T35-91**.

**Notes**

- ① 690V is available only from T18 thru V85. Not available on U-Frames.
- ② 500A rating does not have IEC certification.
- ③ For more information on optimum performance of the 1000A Frame Size V S811, see Appendix E of MN03902002E.

S811



**Standard Duty—15 Second Ramp, 4 Starts per Hour, 450% Current Limit at 40°C**

Max. Current	Three-Phase Motors kW Rating (50 Hz)			hp Rating (60 Hz)				575–690V <sup>①</sup>				Catalog Number
	230V	380–400V	440V	200V 1.0SF	1.15SF	230V 1.0SF	1.15SF	460V 1.0SF	1.15SF	1.0SF	1.15SF	
<b>Frame Size N</b>												
29	7.5	12.5	15	7-1/2	7-1/2	10	7-1/2	20	15	25	20	<b>S811N37N3S</b>
49	12.5	22	25	15	10	15	15	30	30	40	40	<b>S811N66N3S</b>
<b>Frame Size R</b>												
73	18.5	37	40	20	20	25	20	50	40	60	60	<b>S811R10N3S</b>
94	25	45	55	30	25	30	30	60	60	75	75	<b>S811R13N3S</b>
<b>Frame Size T</b>												
155	45	80	90	50	40	60	50	100	100	150	125	<b>S811T18N3S</b>
219	63	110	132	60	60	75	60	150	150	200	150	<b>S811T24N3S</b>
280	80	150	160	75	75	100	75	200	200	250	250	<b>S811T30N3S</b>
<b>Frame Size U</b>												
345	100	185	200	100	100	125	100	250	200	350	300	<b>S811U36N3S</b>
405	110	200	250	125	100	150	125	300	250	400	350	<b>S811U42N3S</b>
<b>Frame Size V</b>												
345	100	185	200	100	100	125	100	250	200	350	300	<b>S811V36N3S</b>
405	110	200	250	125	100	150	125	300	250	400	350	<b>S811V42N3S</b>
465	140	250	280	150	125	150	150	350	300	450	400	<b>S811V50N3S</b>
530	160	280	335	150	150	200	150	450	350	500	450	<b>S811V65N3S</b>
590	180	315	375	200	150	—	200	500	400	600	500	<b>S811V72N3S</b>
651	200	355	425	—	—	—	—	600	450	700	600	<b>S811V85N3S</b>
754	220	400	465	—	—	—	—	600	500	800	700	<b>S811V10N3S<sup>②</sup></b>

For **Pump Option**, replace character **8** with **“P”** and also, see **Page V6-T35-91**.

**Notes**

- ① 690V is available only from T18 thru V85. Not available on U-Frames.
- ② For more information on optimum performance of the 1000A Frame Size V S811, see Appendix E of MN03902002E.



S811



### Standard Duty—30 Second Ramp, 4 Starts per Hour, 450% Current Limit at 40°C

Max. Current	Three-Phase Motors kW Rating (50 Hz)			hp Rating (60 Hz)				575–690V <sup>①</sup>				Catalog Number
	230V	380–400V	440V	200V 1.0SF	1.15SF	230V 1.0SF	1.15SF	460V 1.0SF	1.15SF	1.0SF	1.15SF	
<b>Frame Size N</b>												
21	5.5	10	12.5	5	5	5	5	15	10	15	15	<b>S811N37N3S</b>
40	11	18.5	22	10	10	10	10	30	25	30	30	<b>S811N66N3S</b>
<b>Frame Size R</b>												
55	15	25	30	15	15	20	15	40	30	50	40	<b>S811R10N3S</b>
75	22	37	45	20	20	25	20	50	50	60	60	<b>S811R13N3S</b>
<b>Frame Size T</b>												
151	45	80	90	50	40	50	50	100	100	150	125	<b>S811T18N3S</b>
215	63	110	132	60	60	75	60	150	150	200	150	<b>S811T24N3S</b>
264	80	140	160	75	75	100	75	200	150	250	200	<b>S811T30N3S</b>
<b>Frame Size U</b>												
300	90	160	185	100	75	100	100	200	200	300	250	<b>S811U36N3S</b>
340	100	180	200	100	100	125	100	250	200	350	300	<b>S811U42N3S</b>
380	110	200	220	125	100	150	125	300	250	350	300	<b>S811U50N3S</b>
<b>Frame Size V</b>												
300	90	160	185	100	75	100	100	200	200	300	250	<b>S811V36N3S</b>
340	100	180	200	100	100	125	100	250	200	350	300	<b>S811V42N3S</b>
380	110	200	220	125	100	150	125	300	250	350	300	<b>S811V50N3S</b>
420	129	220	257	150	125	150	150	350	300	450	350	<b>S811V65N3S</b>
460	140	250	280	150	125	150	150	350	300	450	400	<b>S811V72N3S</b>
500	150	257	300	150	150	200	150	400	350	500	450	<b>S811V85N3S</b>
560	160	277	325	200	150	250	200	500	400	600	500	<b>S811V10N3S<sup>②</sup></b>

For **Pump Option**, replace character **8** with **"P"** and also, see **Page V6-T35-91**.

**Notes**

- ① 690V is available only from T18 thru V85. Not available on U-Frames.
- ② For more information on optimum performance of the 1000A Frame Size V S811, see Appendix E of MN03902002E.

#### Severe Duty

#### Severe Duty Ratings

Starting Method	Ramp Current % of FLA	Ramp Time Seconds	Starts per Hour	Ambient Temperature
Soft start	450%	30 sec.	4	50°C
Full voltage	500%	10 sec.	10	50°C
Wye-delta	350%	65 sec.	3	50°C
80% RVAT	480%	25 sec.	4	50°C
65% RVAT	390%	40 sec.	4	50°C
50% RVAT	300%	60 sec.	4	50°C

Severe duty ratings are defined as any combination of parameters that exceed the standard duty ratings

where the ramp time is over 30 seconds, the number of starts per hour exceeds 4, or the current limit set is over

300%. *Example:* 35-second ramp, 5 starts per hour, 350% current limit at 40°C ambient.

#### S811



#### Severe Duty—>30 Second Ramp, >4 Starts per Hour or >300% Current Limit

Max. Current	Three-Phase Motors kW Rating (50 Hz)				hp Rating (60 Hz)				575–690V ①		Catalog Number	
	230V		380–400V	440V	200V		230V		460V	1.0SF		1.15SF
	1.0SF	1.15SF	1.0SF	1.15SF	1.0SF	1.15SF	1.0SF	1.15SF	1.0SF	1.15SF		
<b>Frame Size N</b>												
22	5.5	10	11	5	5	7-1/2	5	15	10	20	15	<b>S811N37N3S</b>
42	11	18.5	22	10	10	15	10	30	25	40	30	<b>S811N66N3S</b>
<b>Frame Size R</b>												
65	15	30	33	15	15	20	15	50	40	50	50	<b>S811R10N3S</b>
80	22	40	45	25	20	30	25	60	50	75	60	<b>S811R13N3S</b>
<b>Frame Size T</b>												
115	33	59	63	30	30	40	30	75	75	100	100	<b>S811T18N3S</b>
150	45	80	90	50	40	50	50	100	100	150	125	<b>S811T24N3S</b>
192	55	100	110	60	50	75	60	150	125	200	150	<b>S811T30N3S</b>
<b>Frame Size U</b>												
240	75	110	147	75	60	75	75	200	150	200	200	<b>S811U36N3S</b>
305	90	160	185	100	75	100	100	250	200	300	250	<b>S811U42N3S</b>
<b>Frame Size V</b>												
240	75	110	147	75	60	75	75	200	150	200	200	<b>S811V36N3S</b>
305	90	160	185	100	75	100	100	250	200	300	250	<b>S811V42N3S</b>
365	110	185	220	125	100	150	125	300	250	350	300	<b>S811V50N3S</b>
420	129	220	257	150	125	150	150	350	300	450	350	<b>S811V65N3S</b>
480	147	257	295	150	150	200	150	400	350	500	450	<b>S811V72N3S</b>
525	160	280	335	150	150	200	150	450	350	500	450	<b>S811V85N3S</b>
575	172	303	370	200	150	250	200	500	450	600	500	<b>S811V10N3S</b> ②

#### Notes

① 690V is available only from T18 thru V85. Not available on U-Frames.

② For more information on optimum performance of the 1000A Frame Size V S811, see Appendix E of MN03902002E.

### Inside-the-Delta Standard Duty Ratings

S811



### Inside-the-Delta Standard Duty—15 Second Ramp, 4 Starts per Hour, 300% Current Limit at 40°C Ambient

Max. Continuous Motor Line Current	Three-Phase Motor kW Rating (50 Hz)			hp Rating (60 Hz)								Catalog Number
	230V	380–400V	440V	200V		230V		460V		575V		
				1.0SF	1.15SF	1.0SF	1.15SF	1.0SF	1.15SF	1.0SF	1.15SF	
<b>Frame Size N</b>												
65	10	18.5	18.5	15	15	15	15	40	30	50	50	<b>S811N37N3D</b>
114	18.5	30	37	30	25	30	30	75	60	100	75	<b>S811N66N3D</b>
<b>Frame Size R</b>												
182	30	55	59	50	40	60	50	125	100	150	125	<b>S811R10N3D</b>
234	40	63	80	60	50	75	60	150	125	200	150	<b>S811R13N3D</b>
<b>Frame Size T</b>												
311	51	90	110	100	75	100	100	250	200	250	250	<b>S811T18N3D</b>
415	75	110	147	125	100	125	125	300	250	300	300	<b>S811T24N3D</b>
526	90	160	185	150	125	150	150	400	300	400	400	<b>S811T30N3D</b>
<b>Frame Size U</b>												
623	110	185	220	200	150	250	200	450	400	550	450	<b>S811U36N3D</b>
727	129	220	257	250	200	300	250	550	450	700	550	<b>S811U42N3D</b>
865	150	257	300	250	250	300	250	600	550	750	700	<b>S811U50N3D</b> <sup>①②</sup>
<b>Frame Size V</b>												
623	110	185	220	200	150	250	200	450	400	550	450	<b>S811V36N3D</b>
727	129	220	257	250	200	300	250	550	450	700	550	<b>S811V42N3D</b>
865	150	257	300	250	250	300	250	600	550	750	700	<b>S811V50N3D</b>
1125	200	355	425	400	300	400	300	750	700	900	750	<b>S811V65N3D</b>
1246	—	—	—	—	—	—	—	—	—	—	—	<b>S811V72N3D</b>
1471	—	—	—	—	—	—	—	—	—	—	—	<b>S811V85N3D</b>
—	—	—	—	—	—	—	—	—	—	—	—	<b>S811V10N3D</b> <sup>③</sup>

**Notes**

- ① 15 sec. start, 300% inrush, 40°C, 1 start every 15 minutes. If these start parameters are exceeded, please refer to 290 mm V-Frame, 865A inside-the-delta starter.
- ② U-Frame 500A unit does not have IEC certification.
- ③ For more information on optimum performance of the 1000A Frame Size V S811, see Appendix E of MN03902002E.

S811



#### Inside-the-Delta Standard Duty—25 Second Ramp, 4 Starts per Hour, 300% Current Limit at 40°C Ambient

Max. Continuous Motor Line Current	Three-Phase Motor kW Rating (50 Hz)			hp Rating (60 Hz)								Catalog Number
	230V	380–400V	440V	200V 1.0SF	1.15SF	230V 1.0SF	1.15SF	460V 1.0SF	1.15SF	575V 1.0SF	1.15SF	
<b>Frame Size N</b>												
58	9	15	18.5	15	10	15	15	40	30	50	40	<b>S811N37N3D</b>
108	15	30	33	30	25	30	30	60	60	100	75	<b>S811N66N3D</b>
<b>Frame Size R</b>												
164	25	45	55	50	40	50	50	125	100	125	125	<b>S811R10N3D</b>
206	33	63	63	60	50	60	50	125	125	150	150	<b>S811R13N3D</b>
<b>Frame Size T</b>												
257	45	80	90	75	60	75	60	150	150	250	200	<b>S811T18N3D</b>
365	63	110	132	100	100	125	100	250	250	300	250	<b>S811T24N3D</b>
477	80	147	160	125	125	150	125	300	300	400	400	<b>S811T30N3D</b>
<b>Frame Size U</b>												
554	90	160	185	150	125	200	150	400	300	450	400	<b>S811U36N3D</b>
646	110	200	220	200	150	250	200	500	400	550	450	<b>S811U42N3D</b>
796	140	250	280	250	200	250	250	550	500	700	600	<b>S811U50N3D</b> <sup>①②</sup>
<b>Frame Size V</b>												
554	90	160	185	150	125	200	150	400	300	450	400	<b>S811V36N3D</b>
646	110	200	220	200	150	250	200	500	400	550	450	<b>S811V42N3D</b>
796	140	250	280	250	200	250	250	550	500	700	600	<b>S811V50N3D</b>
1055	185	315	375	400	250	300	300	800	700	900	750	<b>S811V65N3D</b>
1176	200	375	445	—	300	400	300	900	800	900	900	<b>S811V72N3D</b>
1358	—	—	—	—	—	—	—	—	—	—	—	<b>S811V85N3D</b>
—	—	—	—	—	—	—	—	—	—	—	—	<b>S811V10N3D</b> <sup>③</sup>

**Notes**

- ① 15 sec. start, 300% inrush, 40°C, 1 start every 15 minutes. If these start parameters are exceeded, please refer to 290 mm V-Frame, 796A inside-the-delta starter.
- ② U-Frame 500A unit does not have IEC certification.
- ③ For more information on optimum performance of the 1000A Frame Size V S811, see Appendix E of MN03902002E.

S811



**Inside-the-Delta Standard Duty—15 Second Ramp, 4 Starts per Hour, 300% Current Limit at 50°C Ambient**

Max. Continuous Motor Line Current	Three-Phase Motor kW Rating (50 Hz)			hp Rating (60 Hz)							Catalog Number	
	230V	380–400V	440V	200V 1.0SF	1.15SF	230V 1.0SF	1.15SF	460V 1.0SF	1.15SF	575V 1.0SF		1.15SF
<b>Frame Size N</b>												
58	9	15	18.5	15	10	15	15	40	30	50	40	S811N37N3D
108	15	30	33	30	25	30	30	60	60	100	75	S811N66N3D
<b>Frame Size R</b>												
164	25	45	55	50	40	50	50	125	100	125	125	S811R10N3D
206	33	63	63	60	50	60	60	125	125	150	150	S811R13N3D
<b>Frame Size T</b>												
257	45	80	90	75	60	75	75	150	150	250	200	S811T18N3D
365	63	110	132	100	100	125	100	250	250	300	250	S811T24N3D
477	80	147	160	125	125	150	125	300	300	400	400	S811T30N3D
<b>Frame Size U</b>												
554	90	160	185	150	125	200	150	400	300	450	400	S811U36N3D
646	110	200	220	200	150	250	200	450	400	550	450	S811U42N3D
796	140	250	280	250	200	250	250	550	450	700	600	S811U50N3D ①
<b>Frame Size V</b>												
554	90	160	185	150	125	200	150	400	300	450	400	S811V36N3D
646	110	200	220	200	150	250	200	450	400	550	450	S811V42N3D
796	140	250	280	250	200	250	250	550	450	700	600	S811V50N3D
1055	185	315	375	400	250	300	300	750	700	900	750	S811V65N3D
1176	200	375	445	—	—	—	—	—	—	—	—	S811V72N3D
1358	257	450	500	—	—	—	—	—	—	—	—	S811V85N3D
—	—	—	—	—	—	—	—	—	—	—	—	S811V10N3D ②

**Notes**

- ① U-Frame 500A unit does not have IEC certification.
- ② For more information on optimum performance of the 1000A Frame Size V S811, see Appendix E of MN03902002E.

S811



**Inside-the-Delta Standard Duty—50 Second Ramp, 2 Starts per Hour, 300% Current Limit at 50°C Ambient**

Max. Continuous Motor Line Current	Three-Phase Motor												Catalog Number
	kW Rating (50 Hz)			hp Rating (60 Hz)									
	230V	380–400V	440V	200V		230V		460V		575V			
			1.0SF	1.15SF	1.0SF	1.15SF	1.0SF	1.15SF	1.0SF	1.15SF			
<b>Frame Size N</b>													
36	5.5	10	11	7-1/2	7-1/2	7-1/2	7-1/2	25	15	25	25	<b>S811N37N3D</b>	
73	11	18.5	22	15	15	25	15	50	40	60	50	<b>S811N66N3D</b>	
<b>Frame Size R</b>													
103	15	30	33	25	25	30	25	60	60	75	75	<b>S811R10N3D</b>	
138	22	40	45	40	30	50	40	100	75	125	100	<b>S811R13N3D</b>	
<b>Frame Size T</b>													
199	33	59	63	50	50	60	50	125	125	150	150	<b>S811T18N3D</b>	
257	45	80	90	75	60	75	75	150	150	250	200	<b>S811T24N3D</b>	
324	55	100	110	100	75	100	100	250	200	300	250	<b>S811T30N3D</b>	
<b>Frame Size U</b>													
485	80	150	160	125	125	150	125	300	300	400	400	<b>S811U36N3D</b>	
580	100	180	200	150	150	200	150	400	300	550	450	<b>S811U42N3D</b>	
646	110	200	220	200	150	250	200	450	400	550	450	<b>S811U50N3D</b> <sup>①</sup>	
<b>Frame Size V</b>													
485	80	150	160	125	125	150	125	300	300	400	400	<b>S811V36N3D</b>	
580	100	180	200	150	150	200	150	400	300	550	450	<b>S811V42N3D</b>	
646	110	200	220	200	150	250	200	450	400	550	450	<b>S811V50N3D</b>	
727	129	220	257	250	200	250	250	550	500	700	550	<b>S811V65N3D</b>	
816	147	257	295	250	250	300	250	600	550	750	700	<b>S811V72N3D</b>	
1021	180	315	375	300	250	300	300	750	600	900	750	<b>S811V85N3D</b>	
—	—	—	—	—	—	—	—	—	—	—	—	<b>S811V10N3D</b> <sup>②</sup>	

**Notes**

- ① U-Frame 500A unit does not have IEC certification.
- ② For more information on optimum performance of the 1000A Frame Size V S811, see Appendix E of MN03902002E.

S811



### Inside-the-Delta Standard Duty—15 Second Ramp, 4 Starts per Hour, 450% Current Limit at 40°C Ambient

Max. Continuous Motor Line Current	Three-Phase Motor kW Rating (50 Hz)			hp Rating (60 Hz)								Catalog Number
	230V	380–400V	440V	200V		230V		460V		575V		
				1.0SF	1.15SF	1.0SF	1.15SF	1.0SF	1.15SF	1.0SF	1.15SF	
<b>Frame Size N</b>												
47	7.5	12.5	15	10	10	15	10	30	25	40	30	<b>S811N37N3D</b>
83	12.5	22	25	25	15	25	25	50	50	60	60	<b>S811N66N3D</b>
<b>Frame Size R</b>												
126	18.5	37	40	30	30	40	30	75	60	100	100	<b>S811R10N3D</b>
162	25	45	55	50	40	50	50	100	100	125	125	<b>S811R13N3D</b>
<b>Frame Size T</b>												
266	45	80	90	75	60	100	75	150	150	250	200	<b>S811T18N3D</b>
379	63	110	132	100	100	125	100	250	250	300	250	<b>S811T24N3D</b>
485	80	150	160	125	125	150	125	300	300	400	400	<b>S811T30N3D</b>
<b>Frame Size U</b>												
580	100	185	200	150	150	200	150	400	300	550	450	<b>S811U36N3D</b>
695	110	200	250	200	150	250	200	450	400	600	550	<b>S811U42N3D</b>
798	140	250	280	250	200	250	250	550	450	700	600	<b>S811U50N3D</b> <sup>①</sup>
<b>Frame Size V</b>												
580	100	185	200	150	150	200	150	400	300	550	450	<b>S811V36N3D</b>
695	110	200	250	200	150	250	200	450	400	600	550	<b>S811V42N3D</b>
798	140	250	280	250	200	250	250	550	450	700	600	<b>S811V50N3D</b>
908	160	280	335	250	250	300	250	700	550	750	700	<b>S811V65N3D</b>
1021	—	—	—	—	—	—	—	—	—	—	—	<b>S811V72N3D</b>
1125	—	—	—	—	—	—	—	—	—	—	—	<b>S811V85N3D</b>

**Note**

① U-Frame 500A unit does not have IEC certification.

S811



**Inside-the-Delta Standard Duty—30 Second Ramp, 4 Starts per Hour, 450% Current Limit at 40°C Ambient**

Max. Continuous Motor Line Current	Three-Phase Motor												Catalog Number
	kW Rating (50 Hz)			hp Rating (60 Hz)									
	230V	380–400V	440V	200V		230V		460V		575V			
			1.0SF	1.15SF	1.0SF	1.15SF	1.0SF	1.15SF	1.0SF	1.15SF			
<b>Frame Size N</b>													
36	5.5	10	12.5	7-1/2	7-1/2	7-1/2	7-1/2	25	15	25	25	<b>S811N37N3D</b>	
69	11	18.5	22	15	15	15	15	50	40	50	50	<b>S811N66N3D</b>	
<b>Frame Size R</b>													
96	15	25	30	25	25	30	25	60	50	75	60	<b>S811R10N3D</b>	
130	22	37	45	30	30	40	30	75	75	100	100	<b>S811R13N3D</b>	
<b>Frame Size T</b>													
257	45	80	90	75	60	75	75	150	150	250	200	<b>S811T18N3D</b>	
365	63	110	132	100	100	125	100	250	250	300	250	<b>S811T24N3D</b>	
448	80	140	160	125	125	150	125	300	250	400	300	<b>S811T30N3D</b>	
<b>Frame Size U</b>													
503	90	160	185	150	125	150	150	300	300	450	400	<b>S811U36N3D</b>	
580	100	180	200	150	150	200	150	400	300	550	450	<b>S811U42N3D</b>	
646	110	200	220	200	150	250	200	450	400	550	450	<b>S811U50N3D</b> ①	
<b>Frame Size V</b>													
503	90	160	185	150	125	150	150	300	300	450	400	<b>S811V36N3D</b>	
580	100	180	200	150	150	200	150	400	300	550	450	<b>S811V42N3D</b>	
646	110	200	220	200	150	250	200	450	400	550	450	<b>S811V50N3D</b>	
727	129	220	257	250	200	250	250	550	450	700	550	<b>S811V65N3D</b>	
796	—	—	—	—	—	—	—	—	—	—	—	<b>S811V72N3D</b>	
865	—	—	—	—	—	—	—	—	—	—	—	<b>S811V85N3D</b>	

**Note**

① U-Frame 500A unit does not have IEC certification.



### Inside-the-Delta Severe Duty Ratings

Severe duty ratings are defined as any combination of parameters that exceed the standard duty ratings where the ramp time is over 30 seconds, the number of starts per hour exceeds 4, or the current limit set is over 300%.

Example: 35-second ramp, 5 starts per hour 350% current limit at 40°C ambient.

S811



### Inside-the-Delta Severe Duty

Max. Continuous Motor Line Current	Three-Phase Motor												Catalog Number
	kW Rating (50 Hz)			hp Rating (60 Hz)									
	230V	380–400V	440V	200V		230V		460V		575V			
			1.0SF	1.15SF	1.0SF	1.15SF	1.0SF	1.15SF	1.0SF	1.15SF			
<b>Frame Size N</b>													
39	5.5	10	11	7-1/2	7-1/2	10	7-1/2	25	15	30	25	<b>S811N37N3D</b>	
73	11	18.5	22	15	15	25	15	50	40	60	50	<b>S811N66N3D</b>	
<b>Frame Size R</b>													
111	15	30	33	25	25	30	25	75	60	75	75	<b>S811R10N3D</b>	
138	22	40	45	40	30	50	40	100	75	120	100	<b>S811R13N3D</b>	
<b>Frame Size T</b>													
199	33	59	63	50	50	60	50	125	125	150	150	<b>S811T18N3D</b>	
257	45	80	90	75	60	75	75	150	150	250	200	<b>S811T24N3D</b>	
324	55	100	110	100	75	100	100	250	200	300	250	<b>S811T30N3D</b>	
<b>Frame Size U</b>													
415	75	110	147	125	100	125	125	300	250	300	300	<b>S811U36N3D</b>	
526	90	160	185	150	120	150	150	400	300	450	400	<b>S811U42N3D</b>	
623	110	185	220	200	150	250	200	450	400	550	450	<b>S811U50N3D</b> ①	
<b>Frame Size V</b>													
415	75	110	147	125	100	125	125	300	250	300	300	<b>S811V36N3D</b>	
526	90	160	185	150	120	150	150	400	300	450	400	<b>S811V42N3D</b>	
623	110	185	220	200	150	250	200	450	400	550	450	<b>S811V50N3D</b>	
727	129	220	257	250	200	250	250	550	450	700	550	<b>S811V65N3D</b>	
816	147	257	295	250	250	300	250	600	550	750	700	<b>S811V72N3D</b>	
908	160	280	335	250	250	300	250	700	550	750	700	<b>S811V85N3D</b>	
												<b>S811V10N3D</b> ②	

**Notes**

- ① U-Frame 500A unit does not have IEC certification.
- ② For more information on optimum performance of the 1000A Frame Size V S811, see Appendix E of MN03902002E.

### Accessories

#### Lug Kits

The T and U frame (200 mm) and V frame (290 mm) each have different lug options based on your wiring needs.

The T and U frame (200 mm) and V frame (290 mm) soft starters each have different lug options based on your wiring needs. Each lug kit contains three lugs that can be mounted on either the load or line side.

#### Lug Kit



#### Lug Kits

Frame Size	Frame Designation	Description	Catalog Number
200 mm SSRV	T, U	2 cable connections, 4 AWG to 1/0 cable	<b>EML22</b>
		1 cable connection, 4/0 to 500 kcmil cable	<b>EML23</b>
		2 cable connections, 4/0 to 500 kcmil cable	<b>EML24</b>
		1 cable connection, 2/0 to 300 kcmil cable	<b>EML25</b>
		2 cable connections, 2/0 to 300 kcmil cable	<b>EML26</b>
		290 mm SSRV	V
4 cable connections, 4/0 to 500 kcmil cable	<b>EML30</b>		
6 cable connections, 4/0 to 500 kcmil cable	<b>EML32</b>		
4 cable connections, 2/0 to 300 kcmil cable	<b>EML33</b> <sup>①</sup>		

#### Power Supplies

24 Vdc power supply that can be used with the S811 SSRV or as a stand-alone device.

#### Power Supplies

Description	Catalog Number
85–264 Vac input 24 Vdc output	<b>PSG240E</b>
360–575 Vac input 24 Vdc output	<b>PSG240F</b>

#### Lug Cover Kits

Replacement covers for the T- and V-Frame are available in case of damage to the existing covers.

#### Lug Cover Kits

Description	Catalog Number
Lug cover T-, U-Frame	<b>EML27</b>
Lug cover V-Frame	<b>EML34</b>

#### IP20 Kits

#### IP20 Kits

Description	Catalog Number
N-Frame kit	<b>SS-IP20-N</b>
R-Frame kit	<b>SS-IP20-R</b>
T- and U-Frame kit	<b>SS-IP20-TU</b>
V-Frame kit	<b>SS-IP20-V</b>

#### Surge Suppressors

The surge suppressor can mount on either the line or load side of the **IT** Soft Starter. It is designed to clip the line voltage (or load side induced voltage).

#### Surge Suppressor



#### Surge Suppressors

Description	Catalog Number
600V MOV for 200 mm and 290 mm units	<b>EMS39</b>
690V MOV for 200 mm and 290 mm units <sup>②</sup>	<b>EMS41</b>

#### Notes

- ① The EML33 does not have a CSA listing.
- ② T-Frame only.
- ③ For more information, see Pub. 51719.

### Mounting Plates

The mounting plates are designed to help make it easy to install or retrofit the soft starter into enclosures and MCCs. The soft starter can be mounted onto the plate prior to installation. The mounting plate is designed with tear drop mounting holes for easier installation.

### Mounting Plates

Description	Catalog Number
Mounting Plate N-Frame	EMM13N
Mounting Plate R-Frame	EMM13R
Mounting Plate T-, U-Frame	EMM13T
Mounting Plate V-Frame	EMM13V

### Vibration Plates

The vibration plates allow the soft starter to be applied in high shock and vibration applications. The vibration plate allows vibration up to 5g and shock in up to 40g. The soft starter is mounted onto the vibration plate prior to installation in the panel.

### Vibration Plates

Description	Catalog Number
Vibration plate N-Frame	EMM14N
Vibration plate R-Frame	EMM14R
Vibration plate T-, U-Frame	EMM14T
Vibration plate V-Frame	EMM14V

### Adapter Plates

The adapter plate allows customers to retrofit a V-Frame 290 mm soft starter with the U-Frame 200 mm soft starter.

### Adapter Plates

Description	Catalog Number
Adapter plates <sup>②</sup>	EMM13U

### Control Wire Connector

### Control Wire Connector

Description	Catalog Number
12-pin, 5 mm pitch connector for control wiring	EMA75

### Control Interface Module

The Control Interface Module (CIM) is available as a replacement part in two versions.

### CIM

Description	Catalog Number
Blank cover (filler)	EMA68
CIM for standard unit	EMA71
CIM for pump control option	EMA72
Panel mounting kit	
3 ft cable	EMA69A
5 ft cable	EMA69B
8 ft cable	EMA69C
10 ft cable	EMA69D

## Options

### Pump Control

For pump control option, change the **8th** digit in the catalog number to **P**.

### Pump Control Option

Frame Size	Max. Current	Catalog Number
N	37	S811N37P3S
	66	S811N66P3S
R	105	S811R10P3S
	135	S811R13P3S
T	180	S811T18P3S
	240	S811T24P3S
	304	S811T30P3S
U	360	S811U36P3S
	420	S811U42P3S
	500	S811U50P3S <sup>①</sup>
V	360	S811V36P3S
	420	S811V42P3S
	500	S811V50P3S
	650	S811V65P3S
	720	S811V72P3S
	850	S811V85P3S
1000	S811V10P3S	

### Extended Ramp

For a longer ramp acceleration time of 0.5–360 seconds, change the last digit in the catalog number from **Page V6-T35-76** to **L**.

### Extended Ramp Option

Frame Size	Max. Current	Catalog Number
N	37	S811N37N3L
	66	S811N66N3L
R	105	S811R10N3L
	135	S811R13N3L
T	180	S811T18N3L
	240	S811T24N3L
	304	S811T30N3L
U	360	S811U36N3L
	420	S811U42N3L
	500	S811U50N3L <sup>①</sup>
V	360	S811V36N3L
	420	S811V42N3L
	500	S811V50N3L
	650	S811V65N3L
	720	S811V72N3L
	850	S811V85N3L
1000	S811V10N3L	

### Extended Ramp and 690V Option

690V ratings are available on the T- and V-Frames by changing the **8th** digit in the 0.0 to **V**.

### 690V Option

Frame Size	Max. Current	Catalog Number
T	180	S811T18V3L
	240	S811T24V3L
	304	S811T30V3L
V	360	S811V36V3L
	420	S811V42V3L
	500	S811V50V3L
	650	S811V65V3L
	720	S811V72V3L
850	S811V85V3L	

### Cooling Fan Kit

The EMM18 cooling fan kit mounts on either side of any frame size S801 Soft Starter to provide additional printed circuit board cooling in high ambient operating temperatures.

### Cooling Fan Kit

Description	Catalog Number
Fan Kit	EMM18

### Notes

- <sup>①</sup> U-Frame 500A unit does not have IEC certification.
- <sup>②</sup> For more information, see Pub 51719.

## Technical Data and Specifications

## /T. Soft Starters—S811

Description	S811 Soft Starter (Partial Catalog Number)			
	S811N37	S811N66	S811R10	S811R13
Max. current capacity	37	66	105	135
FLA range	11–37	20–66	32–105	42–135
<b>General Information</b>				
Bypass mechanical lifespan	10M	10M	10M	10M
Insulating voltage Ui	660V	660V	660V	660V
Ramp time range	0.5–180 seconds (0.5–360 seconds extended ramp)	0.5–180 seconds (0.5–360 seconds extended ramp)	0.5–180 seconds (0.5–360 seconds extended ramp)	0.5–180 seconds (0.5–360 seconds extended ramp)
Resistance to vibration	3g	3g	3g	3g
Resistance to shock	15g	15g	15g	15g
<b>Electrical Information</b>				
Operating voltage	200–600V	200–600V	200–600V	200–600V
Operating frequency	47–63 Hz	47–63 Hz	47–63 Hz	47–63 Hz
Overload setting	30–100%	30–100%	30–100%	30–100%
Trip class	5, 10, 20 and 30	5, 10, 20 and 30	5, 10, 20 and 30	5, 10, 20 and 30
<b>Cabling Capacity (IEC 947)</b>				
Number of conductors	1	1	1	1
Wire sizes	14–2	14–2	14–4/0	14–4/0
Type of connectors	Box lug	Box lug	Box lug	Box lug
<b>Control Wiring (12-Pin)</b>				
Wire sizes in AWG	22–14	22–14	22–14	22–14
Number of conductors (stranded)	2 (or one AWG 12)	2 (or one AWG 12)	2 (or one AWG 12)	2 (or one AWG 12)
Torque requirements in lb-in	3.5	3.5	3.5	3.5
Solid, stranded or flexible max. size in mm <sup>2</sup>	3.31	3.31	3.31	3.31
<b>Control Power Requirements</b>				
Voltage range (24V ±10%)	21.6–26.4	21.6–26.4	21.6–26.4	21.6–26.4
Steady-state current amps	1.0	1.0	1.0	1.0
Inrush current amps	10	10	10	10
Ripple	1%	1%	1%	1%
<b>Relays (1) Class A and C</b>				
Voltage AC—maximum	240	240	240	240
Voltage DC—maximum	120	120	120	120
Amps—maximum	3	3	3	3
<b>Environment</b>				
Temperature—operating	–30 to 50°C (no derating) consult factory for operation >50°C	–30 to 50°C (no derating) consult factory for operation >50°C	–30 to 50°C (no derating) consult factory for operation >50°C	–30 to 50°C (no derating) consult factory for operation >50°C
Temperature—storage	–50 to 70°C	–50 to 70°C	–50 to 70°C	–50 to 70°C
Altitude	<2000m—consult factory for operation >2000m	<2000m—consult factory for operation >2000m	<2000m—consult factory for operation >2000m	<2000m—consult factory for operation >2000m
Humidity	<95% noncondensing	<95% noncondensing	<95% noncondensing	<95% noncondensing
Operating position	Any	Any	Any	Any
Pollution degree IEC947-1	3	3	3	3
Impulse withstand voltage IEC947-4-1	6000V	6000V	6000V	6000V

**IT. Soft Starters—S811, continued**

Description	S811 Soft Starter (Partial Catalog Number)			
	S811T18	S811T24	S811T30	S811U36
Max. current capacity	180	240	304	360
FLA range	56–180	75–240	95–304	112–360
<b>General Information</b>				
Bypass mechanical lifespan	10M	10M	10M	10M
Insulating voltage $U_i$	660V	660V	660V	660V
Ramp time range	0.5–180 seconds (0.5–360 seconds extended ramp)	0.5–180 seconds (0.5–360 seconds extended ramp)	0.5–180 seconds (0.5–360 seconds extended ramp)	0.5–180 seconds (0.5–360 seconds extended ramp)
Resistance to vibration	3g	3g	3g	3g
Resistance to shock	15g	15g	15g	15g
<b>Electrical Information</b>				
Operating voltage	200–600V	200–600V	200–600V	200–600V
Operating frequency	47–63 Hz	47–63 Hz	47–63 Hz	47–63 Hz
Overload setting	30–100%	30–100%	30–100%	30–100%
Trip class	5, 10, 20 and 30	5, 10, 20 and 30	5, 10, 20 and 30	5, 10, 20 and 30
<b>Cabling Capacity (IEC 947)</b>				
Number of conductors	1 or 2	1 or 2	1 or 2	1 or 2
Wire sizes	4 AWG to 500 kcmil	4 AWG to 500 kcmil	4 AWG to 500 kcmil	4 AWG to 500 kcmil
Type of connectors	Add-on lug kit	Add-on lug kit	Add-on lug kit	Add-on lug kit
<b>Control Wiring (12-Pin)</b>				
Wire sizes in AWG	22–14	22–14	22–14	22–14
Number of conductors (stranded)	2 (or one AWG 12)	2 (or one AWG 12)	2 (or one AWG 12)	2 (or one AWG 12)
Torque requirements in lb-in	3.5	3.5	3.5	3.5
Solid, stranded or flexible max. size in mm <sup>2</sup>	3.31	3.31	3.31	3.31
<b>Control Power Requirements</b>				
Voltage range (24V ±10%)	21.6–26.4	21.6–26.4	21.6–26.4	21.6–26.4
Steady-state current amps	1.0	1.0	1.0	1.0
Inrush current amps	10	10	10	10
Ripple	1%	1%	1%	1%
<b>Relays (1) Class A and C</b>				
Voltage AC—maximum	240	240	240	240
Voltage DC—maximum	120	120	120	120
Amps—maximum	3	3	3	3
<b>Environment</b>				
Temperature—operating	–30 to 50°C (no derating) consult factory for operation >50°C	–30 to 50°C (no derating) consult factory for operation >50°C	–30 to 50°C (no derating) consult factory for operation >50°C	–30 to 50°C (no derating) consult factory for operation >50°C
Temperature—storage	–50 to 70°C	–50 to 70°C	–50 to 70°C	–50 to 70°C
Altitude	<2000m—consult factory for operation >2000m	<2000m—consult factory for operation >2000m	<2000m—consult factory for operation >2000m	<2000m—consult factory for operation >2000m
Humidity	<95% noncondensing	<95% noncondensing	<95% noncondensing	<95% noncondensing
Operating position	Any	Any	Any	Any
Pollution degree IEC947-1	3	3	3	3
Impulse withstand voltage IEC947-4-1	6000V	6000V	6000V	6000V

## IT. Soft Starters—S811, continued

Description	S811 Soft Starter (Partial Catalog Number)			
	S811U42	S811U50 <sup>①</sup>	S811V36	S811V42
Max. current capacity	420	500	360	420
FLA range	131–420	156–500	112–360	131–420
<b>General Information</b>				
Bypass mechanical lifespan	10M	10M	10M	10M
Insulating voltage U <sub>i</sub>	660V	660V	660V	660V
Ramp time range	0.5–180 seconds (0.5–360 seconds extended ramp)	0.5–180 seconds (0.5–360 seconds extended ramp)	0.5–180 seconds (0.5–360 seconds extended ramp)	0.5–180 seconds (0.5–360 seconds extended ramp)
Resistance to vibration	3g	3g	3g	3g
Resistance to shock	15g	15g	15g	15g
<b>Electrical Information</b>				
Operating voltage	200–600V	200–600V	200–600V	200–600V
Operating frequency	47–63 Hz	47–63 Hz	47–63 Hz	47–63 Hz
Overload setting	30–100%	30–100%	30–100%	30–100%
Trip class	5, 10, 20 and 30	5, 10, 20 and 30	5, 10, 20 and 30	5, 10, 20 and 30
<b>Cabling Capacity (IEC 947)</b>				
Number of conductors	1 or 2	1 or 2	2, 4 or 6	2, 4 or 6
Wire sizes	4 AWG to 500 kcmil	4 AWG to 500 kcmil	4 AWG to 500 kcmil	4 AWG to 500 kcmil
Type of connectors	Add-on lug kit	Add-on lug kit	Add-on lug kit	Add-on lug kit
<b>Control Wiring (12-Pin)</b>				
Wire sizes in AWG	22–14	22–14	22–14	22–14
Number of conductors (stranded)	2 (or one AWG 12)	2 (or one AWG 12)	2 (or one AWG 12)	2 (or one AWG 12)
Torque requirements in lb-in	3.5	3.5	3.5	3.5
Solid, stranded or flexible max. size in mm <sup>2</sup>	3.31	3.31	3.31	3.31
<b>Control Power Requirements</b>				
Voltage range (24V ±10%)	21.6–26.4	21.6–26.4	21.6–26.4	21.6–26.4
Steady-state current amps	1.0	1.0	1.4	1.4
Inrush current amps	10	10	10	10
Ripple	1%	1%	1%	1%
<b>Relays (1) Class A and C</b>				
Voltage AC—maximum	240	240	240	240
Voltage DC—maximum	120	120	120	120
Amps—maximum	3	3	3	3
<b>Environment</b>				
Temperature—operating	–30 to 50°C (no derating) consult factory for operation >50°C	–30 to 50°C (no derating) consult factory for operation >50°C	–30 to 50°C (no derating) consult factory for operation >50°C	–30 to 50°C (no derating) consult factory for operation >50°C
Temperature—storage	–50 to 70°C	–50 to 70°C	–50 to 70°C	–50 to 70°C
Altitude	<2000m—consult factory for operation >2000m	<2000m—consult factory for operation >2000m	<2000m—consult factory for operation >2000m	<2000m—consult factory for operation >2000m
Humidity	<95% noncondensing	<95% noncondensing	<95% noncondensing	<95% noncondensing
Operating position	Any	Any	Any	Any
Pollution degree IEC947-1	3	3	3	3
Impulse withstand voltage IEC947-4-1	6000V	6000V	6000V	6000V

**Note**

① U-Frame 500A unit does not have IEC certification.

## IT. Soft Starters—S811, continued

Description	S811 Soft Starter (Partial Catalog Number)				
	S811V50	S811V65	S811V72	S811V85	S811V10 <sup>①</sup>
Max. current capacity	500	650	720	850	1000
FLA range	156–500	203–650	225–720	265–580	320–1000
<b>General Information</b>					
Bypass mechanical lifespan	10M	10M	10M	10M	10M
Insulating voltage Ui	660V	660V	660V	660V	660V
Ramp time range	0.5–180 seconds (0.5–360 seconds extended ramp)	0.5–180 seconds (0.5–360 seconds extended ramp)	0.5–180 seconds (0.5–360 seconds extended ramp)	0.5–180 seconds (0.5–360 seconds extended ramp)	0.5–180 seconds (0.5–360 seconds extended ramp)
Resistance to vibration	3g	3g	3g	3g	3g
Resistance to shock	15g	15g	15g	15g	15g
<b>Electrical Information</b>					
Operating voltage	200–600V	200–600V	200–600V	200–600V	200–600V
Operating frequency	47–63 Hz	47–63 Hz	47–63 Hz	47–63 Hz	47–63 Hz
Overload setting	30–100%	30–100%	30–100%	30–100%	30–100%
Trip class	5, 10, 20 and 30	5, 10, 20 and 30	5, 10, 20 and 30	5, 10, 20 and 30	5, 10, 20 and 30
<b>Cabling Capacity (IEC 947)</b>					
Number of conductors	2, 4 or 6	2, 4 or 6	2, 4 or 6	2, 4 or 6	2, 4 or 6
Wire sizes	2/0 to 500 kcmil	2/0 to 500 kcmil	2/0 to 500 kcmil	2/0 to 500 kcmil	2/0 to 500 kcmil
Type of connectors	Add-on lug kit	Add-on lug kit	Add-on lug kit	Add-on lug kit	Add-on lug kit
<b>Control Wiring (12-Pin)</b>					
Wire sizes in AWG	22–14	22–14	22–14	22–14	22–14
Number of conductors (stranded)	2 (or one AWG 12)	2 (or one AWG 12)	2 (or one AWG 12)	2 (or one AWG 12)	2 (or one AWG 12)
Torque requirements in lb-in	3.5	3.5	3.5	3.5	3.5
Solid, stranded or flexible max. size in mm <sup>2</sup>	3.31	3.31	3.31	3.31	3.31
<b>Control Power Requirements</b>					
Voltage range (24V ±10%)	21.6–26.4	21.6–26.4	21.6–26.4	21.6–26.4	21.6–26.4
Steady-state current amps	1.4	1.4	1.4	1.4	1.4
Inrush current amps	10	10	10	10	10
Ripple	1%	1%	1%	1%	1%
<b>Relays (1) Class A and C</b>					
Voltage AC—maximum	240	240	240	240	240
Voltage DC—maximum	120	120	120	120	120
Amps—maximum	3	3	3	3	3
<b>Environment</b>					
Temperature—operating	–30 to 50°C (no derating) consult factory for operation >50°C	–30 to 50°C (no derating) consult factory for operation >50°C	–30 to 50°C (no derating) consult factory for operation >50°C	–30 to 50°C (no derating) consult factory for operation >50°C	–30 to 50°C (no derating) consult factory for operation >50°C
Temperature—storage	–50 to 70°C	–50 to 70°C	–50 to 70°C	–50 to 70°C	–50 to 70°C
Altitude	<2000m—consult factory for operation >2000m	<2000m—consult factory for operation >2000m	<2000m—consult factory for operation >2000m	<2000m—consult factory for operation >2000m	<2000m—consult factory for operation >2000m
Humidity	<95% noncondensing	<95% noncondensing	<95% noncondensing	<95% noncondensing	<95% noncondensing
Operating position	Any	Any	Any	Any	Any
Pollution degree IEC947-1	3	3	3	3	3
Impulse withstand voltage IEC947-4-1	6000V	6000V	6000V	6000V	6000V

**Note**

① UR recognized product.

### Wiring Diagrams

#### Line Connected Soft Starter

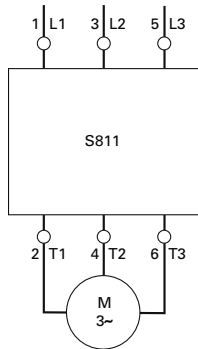

#### Inside-the-Delta Connected Soft Starter for a 6-Lead Motor

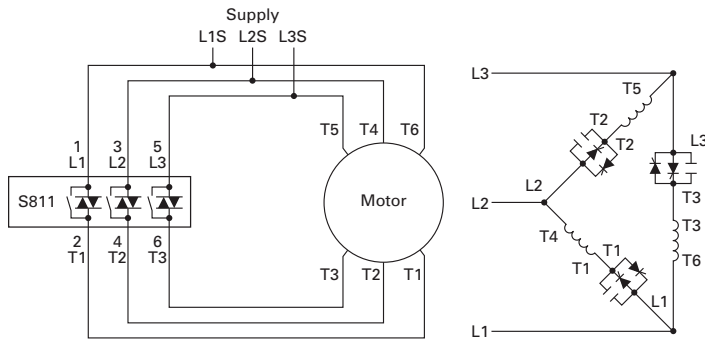

#### Inside-the-Delta Connected Soft Starter for a 12-Lead Low Voltage Motor

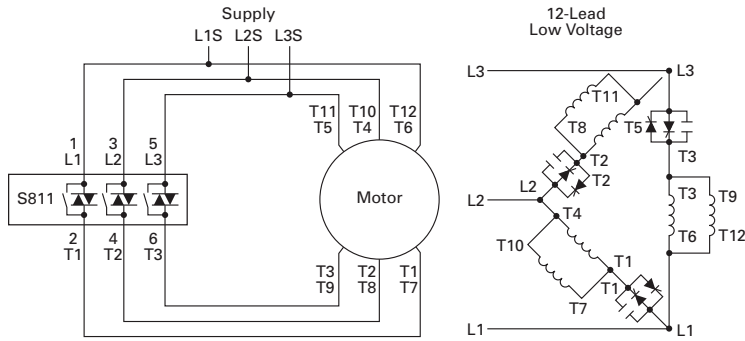

#### Inside-the-Delta Connected Soft Starter for a 12-Lead High Voltage Motor

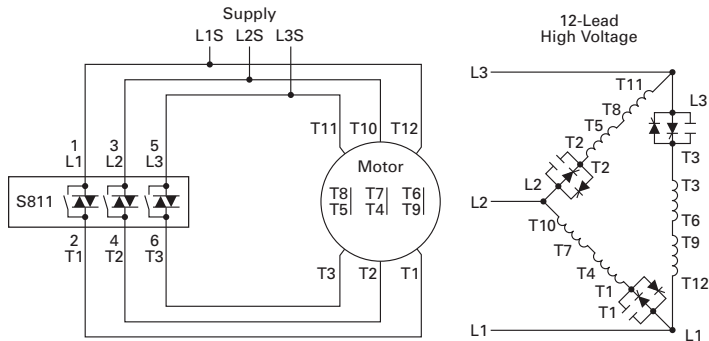



**Dimensions**

Approximate Dimensions in Inches (mm)

**// Soft Starters—S811**

Partial Catalog Number	W	H	D	Weight in Lbs (kg)
S811N37	2.66 (67.6)	7.38 (187.4)	6.47 (164.4)	5.8 (2.6)
S811N66	2.66 (67.6)	7.38 (187.4)	6.47 (164.4)	5.8 (2.6)
S811R10	4.38 (111.3)	7.92 (201.2)	6.66 (169.2)	10.5 (4.8)
S811R13	4.38 (111.3)	7.92 (201.2)	6.66 (169.2)	10.5 (4.8)
S811T18	7.67 (194.8)	12.71 (322.9)	6.39 (162.4)	48 (21.8) with lugs 41 (18.6) without lugs
S811T24	7.67 (194.8)	12.71 (322.9)	6.39 (162.4)	48 (21.8) with lugs 41 (18.6) without lugs
S811T30	7.67 (194.8)	12.71 (322.9)	6.39 (162.4)	48 (21.8) with lugs 41 (18.6) without lugs
S811U36	7.73 (196.3)	12.72 (323.1)	7.08 (179.9)	48 (21.8) with lugs 41 (18.6) without lugs
S811U42	7.73 (196.3)	12.72 (323.1)	7.08 (179.9)	48 (21.8) with lugs 41 (18.6) without lugs
S811U50	7.73 (196.3)	12.72 (323.1)	7.08 (179.9)	48 (21.8) with lugs 41 (18.6) without lugs
S811V36	11.05 (280.6)	16.57 (420.8)	7.35 (186.6)	103 (46.8) with lugs 91 (41.4) without lugs
S811V42	11.05 (280.6)	16.57 (420.8)	7.35 (186.6)	103 (46.8) with lugs 91 (41.4) without lugs
S811V50	11.05 (280.6)	16.57 (420.8)	7.35 (186.6)	103 (46.8) with lugs 91 (41.4) without lugs
S811V65	11.05 (280.6)	16.57 (420.8)	7.35 (186.6)	103 (46.8) with lugs 91 (41.4) without lugs
S811V72	11.05 (280.6)	16.57 (420.8)	7.35 (186.6)	103 (46.8) with lugs 91 (41.4) without lugs
S811V85	11.05 (280.6)	16.57 (420.8)	7.35 (186.6)	103 (46.8) with lugs 91 (41.4) without lugs
S811V10	11.05 (280.6)	16.57 (420.8)	7.35 (186.6)	103 (46.8) with lugs 91 (41.4) without lugs

Also refer to dimension drawings below and on **Pages V6-T35-98 and V6-T35-99.**

**N-Frame (65 mm) S811**

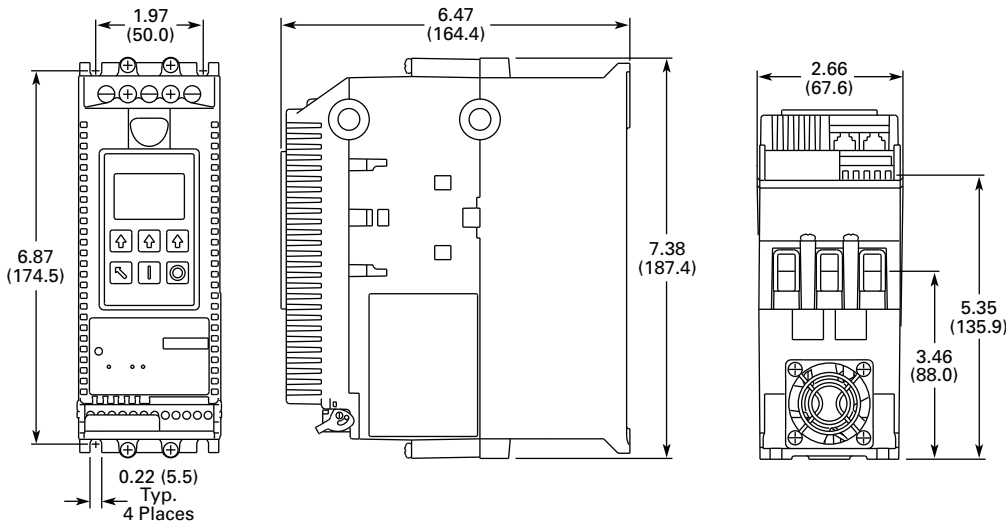

# 35.2 Reduced Voltage Motor Starters

## Solid-State Starters

35

Approximate Dimensions in Inches (mm)

### R-Frame (110 mm) S811

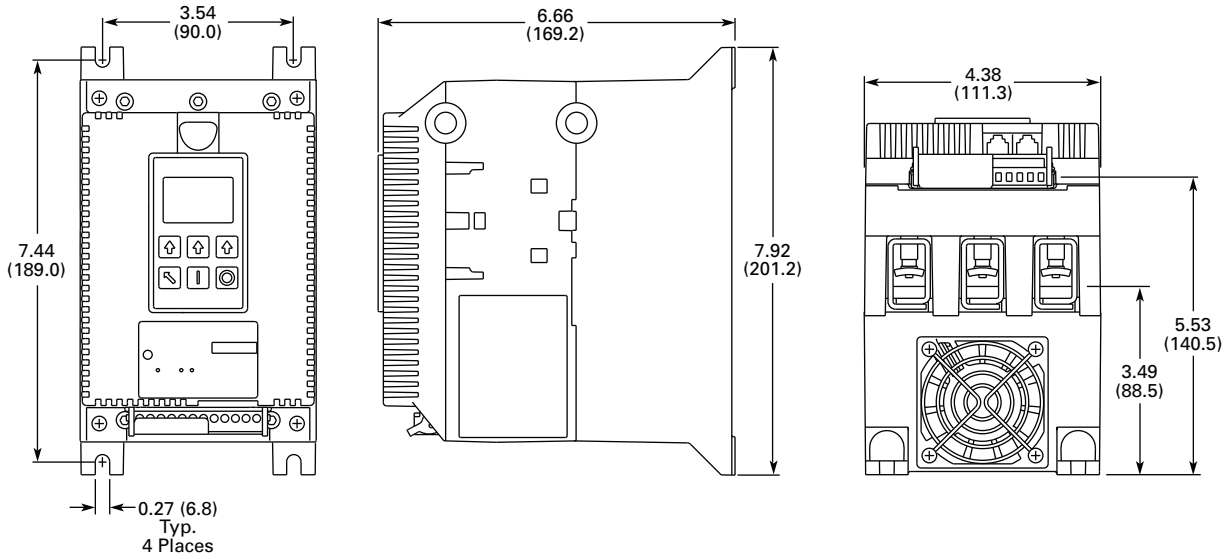

### T-Frame (200 mm) S811

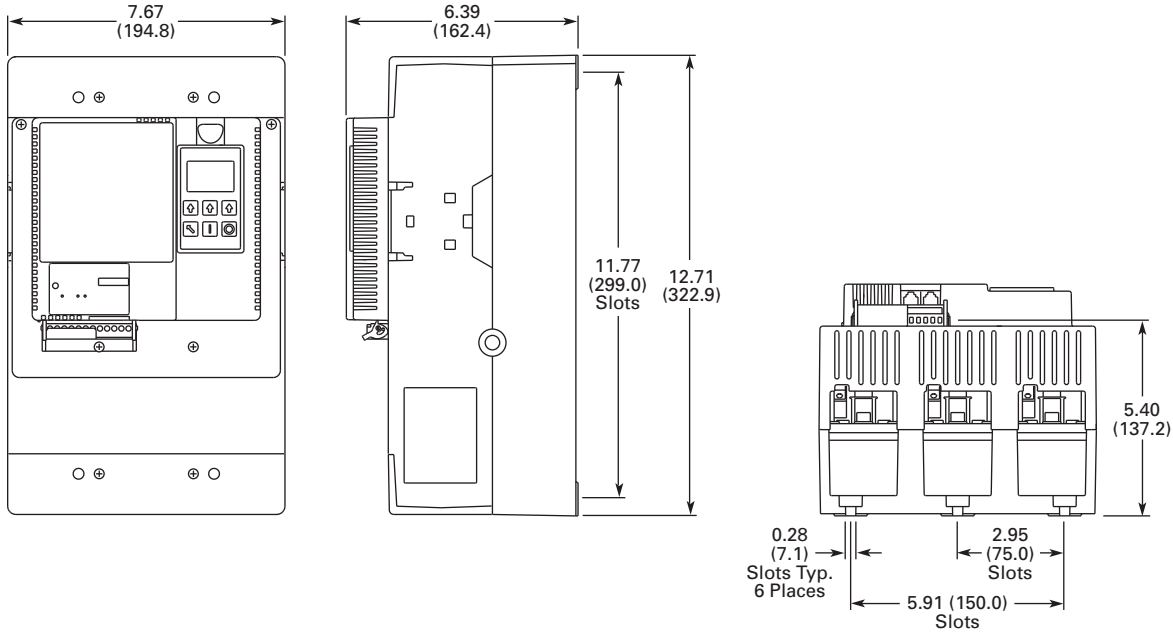

Approximate Dimensions in Inches (mm)

**U-Frame (200 mm) S811**

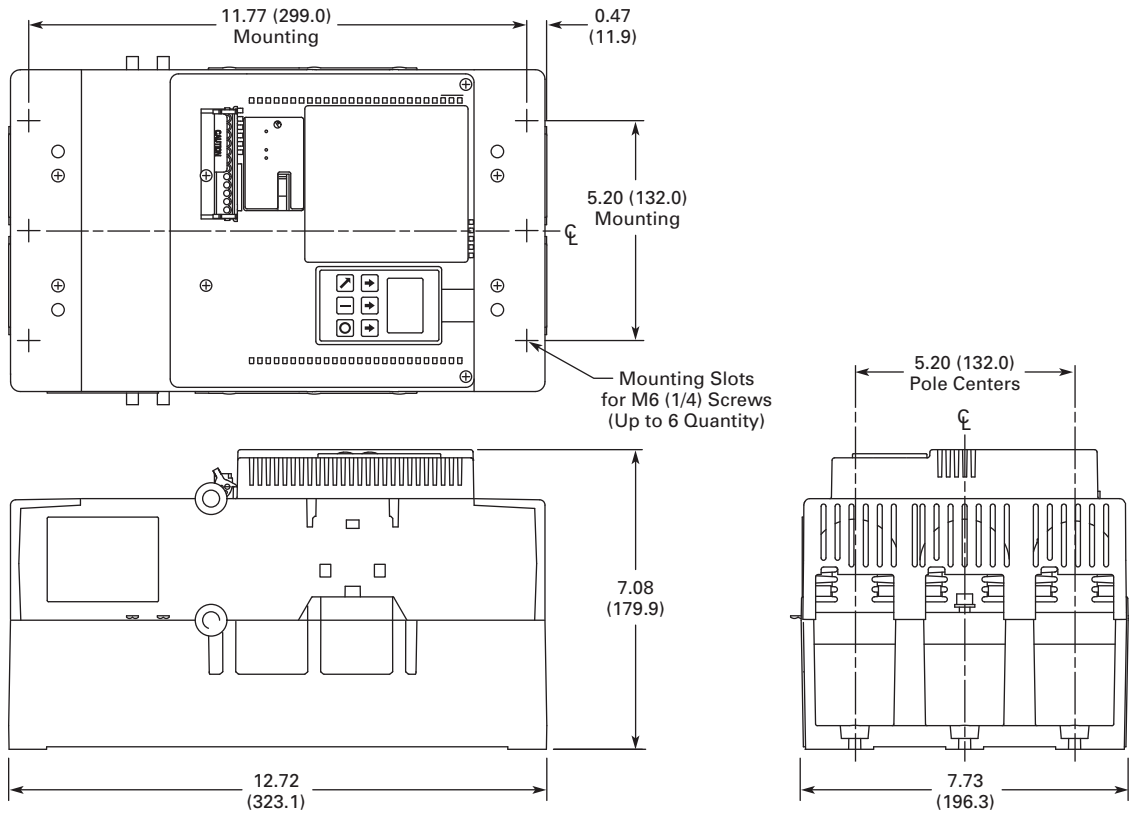

**V-Frame (290 mm) S811**

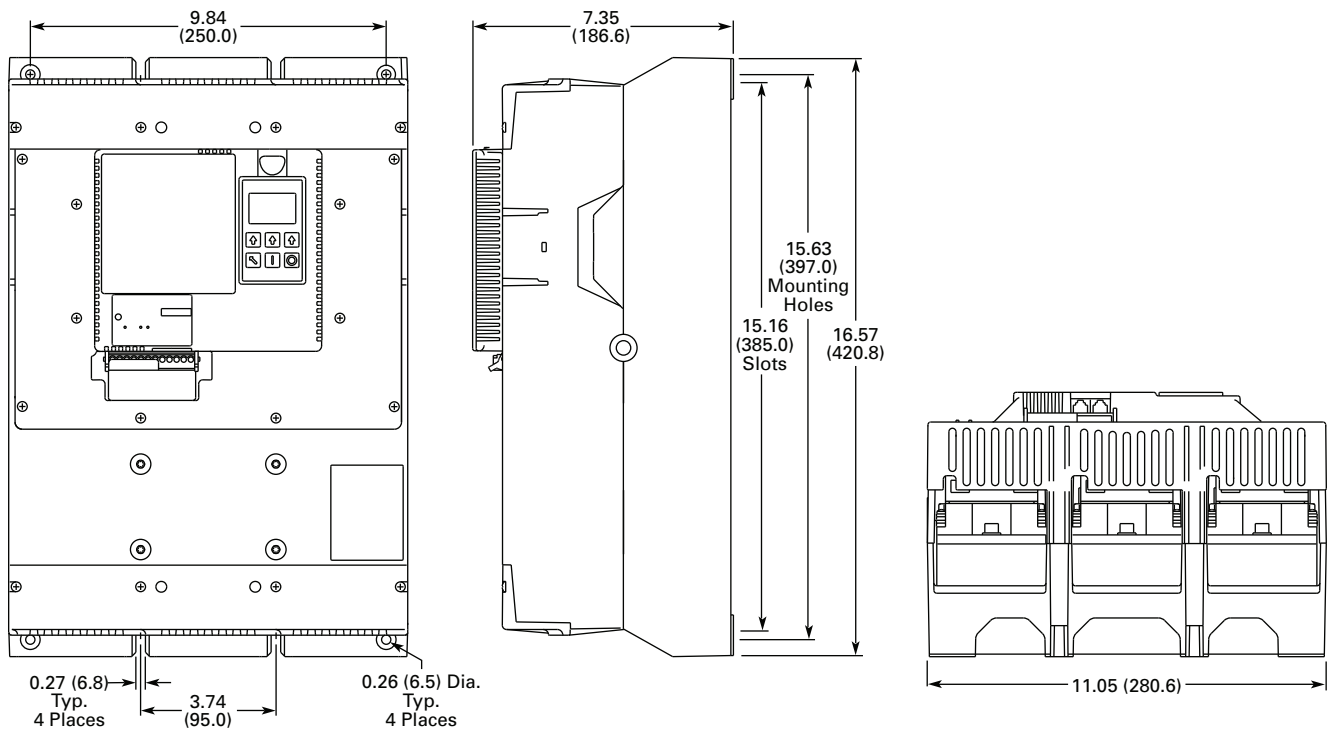

# 35.2

## Reduced Voltage Motor Starters

Solid-State Starters